

A Homeopathic Student's Introduction to Boenninghausen's Therapeutic Pocketbook

Independent Research Project

Keith Wilson

12/2/2008

Overview of the layout and design of Boenninghausen's Therapeutic Pocketbook first published in 1846. An examination of the key differences between the Pocketbook and the Synthesis repertories. A discussion of the Boenninghausen method with illustrations of rubric selection and analysis including a detailed clinic case example from the T.S.H.M. third year clinic.

Contents

Introduction.....	iii
Part I: A first look at the Pocketbook.....	1
Part II: The Genius of Boenninghausen.....	8
(1) Symptoms consist of three components: sensation, location and modality.	9
(2) Proving and clinical patient symptoms are often incompletely reported.	14
(3) The most reliable symptom features are the modalities.	18
(4) Sensations and modalities are general characteristics.....	20
(5) The more consistent (characteristic) features of symptoms are transferable.	23
(6) The uniqueness of a case is found in its combination of symptoms.	29
Part III: The role of the Repertory	35
Rubrics in the Therapeutic Pocketbook	35
Less detail can be better	38
Rubrics of the Mind and Sensorium	45
Repertory analysis of partial symptom descriptions	45
Part IV: Interpreting the Pocketbook’s analysis	53
Part V: A case from Year III Clinic	58
Deanne – initial interview.....	58
Synthesis analysis: hierarchy of symptoms (with weighting).....	60
Therapeutic Pocketbook analysis: hierarchy of symptoms.....	62
Deanne: differential diagnosis	65
Part VI: Clinical verification in the Therapeutic Pocketbook.....	70
Remedy grade levels	70
Cumulative clinical experience: remedy concordances	71
Part VII: Using the Pocketbook in the study of Materia Medica.....	74
In Summary.....	80
Appendix A: Boenninghausen-like repertorization	81
Appendix B: Our repertory lineage.....	82
Appendix C: Case Studies using the Therapeutic Pocketbook.....	83
Bibliography	89

Introduction

Students of homeopathy are introduced to the repertory very early in their formal training. This introduction begins with an overview of the chapter layout, inevitably Kentian, and the organizational hierarchy of rubrics in those chapters. Over the next three years of study we go on to further detailed explorations of specific chapters and individual rubrics. Becoming an accomplished repertory user is a life-long undertaking. Even with the assistance of computer software repertory and materia medica programs. These programs provide rubric cross references for us, give us master synonyms and concepts, and allow us to search the entire repertory in an instance or quickly generate multiple analysis charts. Most of us struggle with rubric selection during our school years all the while making marginal notes to ourselves on where to find rubrics for specific symptoms and which authors and rubrics are reliable. As new students we are quick to pick up the repertory. Creating analysis charts gives us a certain satisfaction and provides our first taste of “doing” homeopathy. In our haste to begin producing homeopathy the relationship between the repertory and the materia medica can go entirely unexplored. Once we’re submitting repertory charts for our in-school cases we seldom return to this basic issue.

Our introduction to the repertory can include a general overview of its role in case analysis with specific attention to its application and limitations. On this solid foundation we can then construct a more particular knowledge of the repertory’s chapters, the rubrics we can count on, the authors on whom we can always rely and those valuable cross references that associate remote parts of the repertory for us. As an offshoot to discussing Boenninghausen’s Therapeutic Pocketbook I hope to provide an opportunity to explore the place the repertory holds within the process of case analysis and how we can make the best use of it.

Background to the Pocketbook

Even in Hahnemann's day there was a need for an index to the expanding Materia Medica. Hahnemann himself began to compile such a work around 1817. His *Symptomenlexikon* reached four volumes of alphabetically-listed symptoms from his Materia Medica Pura and Chronic Diseases but was never completed. (Howard) Early ongoing attempts at creating an index during the 1820s and 1830s employed a range of techniques from simple alphabetic listing of symptoms to more complex arrangements based on the characterizations of symptoms expounded in the Organon. These ordered arrangements, undertaken by such notable homeopaths as Boenninghausen, Jahr and Hering, made it easier to find specific symptoms. (Dimitriadis, p. 1)

It was Boenninghausen who introduced the first repertory of the homeopathic materia medica. This repertory was published in 1832 and was called the *Systemic Alphabetic Repertory of Antipsoric Remedies* (SRA). With this work Boenninghausen introduced the use of rubrics to summarize lengthy proving symptoms and also introduced a four-tiered remedy grading scheme to indicate clinical reliability. Its organization was no longer merely alphabetic, being arranged now according to the various body regions and systems found in Hahnemann's Materia Medica Pura and Chronic Diseases. In 1835 the second volume of this repertory, the *Systemic Alphabetic Repertory of Non-Antipsoric Remedies* (SRN) was published. These two works comprise the first repertory of Boenninghausen and form the model on which our modern repertories are based. (Dimitriadis, "The First Repertory: Boenninghausen's model for our Profession")

In 1834 Jahr published a repertory based on Boenninghausen's SRA. Its second edition was translated into English under the editorship of Hering. This version later found its way, via Lippe and later on Lee, into Kent's repertory. The content and structure of Kent's repertory is based on Hull's translation of Jahr's third edition, the work of E.J. Lee and C.M. Boger's publications. I won't attempt to outline the lineage of our modern day repertory as this has been done thoroughly by Dimitriadis.¹

¹ Dimitriadis, George. "The First Repertory: Boenninghausen's model for our Profession".

Boenninghausen did not cease his efforts with the publication of his SRA and SRN. At the urging of Hahnemann, he set out to combine these two earlier works into a single volume but gave up the endeavour when he realized that it could not be achieved in a “manageable” form. (Howard) It was while attempting this amalgamation of his two repertories that Boenninghausen realized the approach that would result in his 1846 repertory called *The Therapeutic Pocketbook for Homeopathic Physicians for use at the Bedside and the Study of Materia Medica Pura* – most often referred to as the Therapeutic Pocketbook.

In its original form Boenninghausen’s Therapeutic Pocketbook indexed the 126 remedies from Hahnemann’s *Materia Medica Pura* and *The Chronic Diseases*. T.F. Allen’s 1897 edition of the Pocketbook contained 220 additional remedies and omitted 4 from the original publication – *Angustura* and the three magnetic remedies (*Magnetis poli ambo*, *Magnetis polus arcticus* and *Magnetis polus australis*) – bringing the total to 342 remedies. Allen’s additions are considered incomplete. (Roberts, p. 15)

Part I: A first look at the Pocketbook²

Chapter layout and rubrics

Conceptually, Boenninghausen's Therapeutic Pocketbook is quite unlike Kent's repertory and those modern repertories descended from it (Synthesis and The Complete Repertory). The Pocketbook's layout is dramatically different having only seven chapters compared to forty repertory chapters found in Synthesis. The first thing that strikes you about this repertory, aside from the scant number of chapters it contains, is that it lacks chapter headings based on body regions, something that we have come to expect from Kent's repertory. While the chapters on **Sleep & Dreams**, **Mind & Sensorium**, **Fever** and **Change of General State** seem familiar enough there are chapters called **Sensations and Complaints** and especially **Concordance of Homeopathic Remedies** that appear completely unfathomable. The remaining chapter is called **Parts of the Body and Organs** and it too has an unfamiliar layout at first glance.

Regions of the body can be found listed in the Pocketbook but they appear within a single chapter called **Parts of the Body and Organs**. In this chapter you will find rubrics like: **Parts of the Body and organs – Back – Scapulae**, **Parts of the Body and organs – Ears – External ear**, **Parts of the Body and organs – Lower limbs – Leg; lower**. These rubrics are not unlike those found in Synthesis and contain sub-rubrics referring to more specific locations. However what immediately strikes you is that none of these rubrics refers to any kind of pain or other sensations: they are rubrics of **location only**.

Looking next at the Pocketbook chapter called **Sensations and complaints** we find rubrics like: **Sensations and complaints – Bones – band around; like a**, **Sensations and complaints – External parts of the body and internal organs in general – adhesion of inner parts (sensation as)**, **Sensations and complaints – Glands – pressing – outward; from within** or **Sensations and complaints – Skin – nails – ulcerated**. Each rubric

² All references to Boenninghausen's Therapeutic Pocketbook are to the Radar version 3.0. All references to Encyclopaedia Homeopathica are to version 2.1. All references to Synthesis are to the Radar version 9.2

describes a symptom sensation (subjective experience) or a complaint (objective experience) but contains no indication in which bodily region the sensation/complaint occurred. These rubrics are rubrics of **sensation/complaint only** and they are all gathered together in this single chapter just as all the rubrics of location were together in their own chapter. The table below compares the chapter layout of the Pocketbook with that of the Synthesis repertory.

<u>THERAPEUTIC POCKET BOOK</u>	<u>SYNTHESIS</u>
<ul style="list-style-type: none"> • Mind & Sensorium • Parts of the Body & Organs • Sensations & Complaints • Sleep & Dreams • Fever • Change of General State • Concordance of Homeopathic remedies 	<ul style="list-style-type: none"> • Mind • Vertigo • Head • Eye • Vision • Ear • Hearing • Nose • Face • Mouth • Teeth • Throat • External Throat • Neck • Stomach • Abdomen • Rectum • Stool • Bladder • Kidneys • Prostate • Urethra • Urine • Urinary Organs • Male Genitalia • Female Genitalia • Larynx & Trachea • Respiration • Cough • Expectoration • Chest • Back • Extremities • Sleep • Dreams • Chill • Fever • Perspiration • Skin • Generals

Looking next at the chapter called **Change of general state** we see it is divided into two sections called “Aggravation” and “Amelioration”. Under aggravation you will find rubrics like: **Change of general state – Aggravation – ascending – high; ascending a height, climbing up, Change of general state – Aggravation – cold air; from – dry, Change of general state – Aggravation – food and drinks; from partaking certain – meat – smoked, Change of general state – Aggravation – weather – dry weather; during.** Listed under amelioration you will find rubrics such as: **Change of General state – Amelioration – air; in open, Change of general state – Amelioration – head – bending; from – backward, Change of general state – Amelioration – motion; from – continued motion; from.** These rubrics are rubrics of **modality only** and once again they appear in their own exclusive chapter.

The remaining chapters in the Pocketbook function pretty much in the same way. The chapter **Mind and Sensorium** is devoted to mental states and **Sleep and Dreams** to those states. The chapter called **Fever** is extensive and covers conditions of chill, circulation, coldness, heat, perspiration, shivering and stages of fever. The final chapter **Concordance of homeopathic remedies** is set aside to allow broad comparisons between remedies and is especially useful at the time of the follow up consultation.

A few examples should help demonstrate the workings of the Pocketbook’s chapter arrangement. In the first example we’ll take rubrics from Synthesis for the symptom *pulsating pain in the head* and compare them to rubrics from the Pocketbook for this same symptom (Table 1 on the next page). In Synthesis a single rubric from the **Head** chapter, **Head – pain – pulsating**, captures the description of this complaint. The rubric contains a description of where in the body the symptom is found (its location) and also the type and quality of the symptom (its sensation). The configuration of this rubric follows the Kentian convention – chapter [Head]; sensation [pain], sensation [pulsating] – that has become familiar to most students.

Turning to the Therapeutic Pocketbook we see that here it takes two rubrics, each from a different chapter, to cover this same symptom. The first rubric addresses the site of the complaint, which is the head (its location) while the second rubric captures the pulsating

quality of the symptom (its sensation). In the Pocketbook *each rubric is found in a different chapter and covers only a portion of the entire symptom*. Table 1 illustrates suitable rubrics for this example from the Therapeutic Pocketbook and also from Synthesis.

Table 1: Head pain, pulsating	
<u>Therapeutic Pocket Book</u>	<u>Synthesis</u>
<ul style="list-style-type: none"> • Mind & Sensorium • Parts of the Body & Organs <ul style="list-style-type: none"> ○ Internal Head <ul style="list-style-type: none"> ▪ General; in • Sensations & Complaints <ul style="list-style-type: none"> ○ External parts of body and internal organs in general <ul style="list-style-type: none"> ▪ Pulsation <ul style="list-style-type: none"> • Internal parts; in • Sleep & Dreams • Fever • Change of General State • Concordance of Homeopathic remedies 	<ul style="list-style-type: none"> • Mind • Vertigo • Head <ul style="list-style-type: none"> ○ Pain <ul style="list-style-type: none"> ▪ pulsating • Eye • Vision • Ear • Hearing • Nose • Face • Mouth

The breaking apart of symptoms and the dispersal of those parts in different repertory chapters is unique to the Therapeutic Pocketbook and is perhaps the most difficult feature to adjust to when first starting to use it. However, as will be discussed later on, this same arrangement enables flexibility in rubric selection unequalled by any other repertory.

Next we'll take up the symptom *oppression in the upper chest, worse ascending*. This is a more fully described symptom including oppression (a sensation) in the upper chest (a location) that is worse ascending (a modality). This symptom (Table 2) requires two rubrics in Synthesis, as there isn't a single rubric with oppression in the upper chest that also covers worse ascending. Both rubrics, though, are found within the same chapter, **Chest**, one covering the description of oppression (sensation) and also its being worse ascending (modality); while the other rubric addresses the specific site of the complaint in the upper chest (location). You would need to combine these two Synthesis rubrics. Turning to the Therapeutic Pocketbook we see that it requires three rubrics to cover this same symptom. We have a rubric that contains "oppression" (sensation) while another

rubric covers the site of the complaint (location). The third rubric addresses the aggravation from ascending (modality). Once again each Pocketbook rubric covers a single facet of the entire symptom. As a result this more fully described symptom – with its location, sensation and modality – requires three Pocketbook rubrics in order to represent the complete symptom, one for each component of the symptom.

Table 2: upper chest oppression worse ascending

<u>Therapeutic Pocket Book</u>	<u>Synthesis</u>
<ul style="list-style-type: none"> • Mind & Sensorium • Parts of the Body & Organs <ul style="list-style-type: none"> ○ Respiration <ul style="list-style-type: none"> ▪ Oppression of breath ○ Chest <ul style="list-style-type: none"> ▪ Internal chest <ul style="list-style-type: none"> • Upper part • Sensations & complaints • Sleep & dreams • Fever • Change of general state <ul style="list-style-type: none"> ○ Aggravation <ul style="list-style-type: none"> ▪ Ascending from • Concordance of Homeopathic remedies 	<ul style="list-style-type: none"> • Mind • Vertigo • Head • Eye • Vision • Ear • Hearing • Nose • Face • Mouth • Teeth • Throat • External Throat • Neck • Stomach • Abdomen • Rectum • Stool • Bladder • Kidneys • Prostate • Urethra • Urine • Urinary Organs • Male Genitalia • Female Genitalia • Larynx & Trachea • Respiration • Cough • Expectoration • Chest <ul style="list-style-type: none"> ○ Oppression <ul style="list-style-type: none"> ▪ Ascending aggravates ○ Upper part • Back

In the final example we have a symptom: *head pain, boring in nature, located in the occiput and worse ascending* (Table 3). In this symptom we again have a description of a location, a sensation and a modality. In Synthesis we find a rubric, in the **Head** chapter, for pain in the occiput made worse by ascending but the rubric does not contain the quality of boring pain. A second Synthesis rubric, also found in the **Head** chapter, has pain in the occiput that is of a boring nature. So we require two rubrics both located in the same Synthesis chapter. Turning to the Pocket Book we find we again require three rubrics. The first rubric describing the site of the symptom (the occiput) is a location rubric. The second rubric describes the quality of the pain (a boring pain) and is a sensation rubric. The third rubric is a modality rubric (worse from ascending). You may recall that in the preceding example (Table 2: oppressed breathing worse ascending) we found a rubric in the Therapeutic Pocketbook chapter **Change of general state** to cover the aggravation from ascending. In the current example of boring pain in the occiput we have another symptom with the same modality “worse from ascending”. Using the Pocketbook we go back to the chapter **Change of general state** and select the identical rubric used in the previous example, **Aggravation – ascending from**. *In the Therapeutic Pocketbook the same modality rubric can be combined with more than one location or sensation rubric in order to create a new combination of rubrics expressing a new symptom.*

Table3: boring pain in the occiput worse ascending

<u>Therapeutic Pocket Book</u>	<u>Synthesis</u>
<ul style="list-style-type: none"> • Mind & Sensorium • Parts of the body & organs <ul style="list-style-type: none"> ○ Internal head <ul style="list-style-type: none"> ▪ Occiput • Sensations & complaints <ul style="list-style-type: none"> ○ External parts of the body and internal organs in general <ul style="list-style-type: none"> ▪ Boring pain • Sleep & dreams • Fever • Change of general state <ul style="list-style-type: none"> ○ Aggravation <ul style="list-style-type: none"> ▪ Ascending from 	<ul style="list-style-type: none"> • Mind • Vertigo • Head <ul style="list-style-type: none"> ○ Pain <ul style="list-style-type: none"> ▪ Occiput <ul style="list-style-type: none"> • Ascending stairs agg ▪ Occiput <ul style="list-style-type: none"> • Boring pain • Face • Mouth • Teeth • Throat

Now if in the Therapeutic Pocketbook the same modality rubric can be combined with more than one location rubric or more than one sensation rubric then the obvious question at this point would seem to be, “How do you know which of the two locations or sensations this modality really goes with? Or what if it goes with the location but not the sensation? Or is it the other way around? Okay so this is more than one question, but the short answer is that there isn’t any way for you to know. A more complete answer to this question would have to include a qualifier: at the stage of case analysis when you’re searching the repertory for rubrics you really don’t need to know this (at least not yet).

The Therapeutic Pocketbook allows you to select any number of rubrics from one of its chapters and combine them with other rubrics taken from the other chapters. You can choose a rubric from the chapter on locations and combine it with one or more rubrics from the chapter on sensations and then add that to any one or more rubrics from its chapter on modalities, whatever it takes in order to sculpt out the description of the symptom. This is one of the hardest concepts to embrace about the Pocketbook while at the same time it reflects a most remarkable insight from the mind of Boenninghausen. We’ll begin the next section with a closer look at several of these insights all of which are embodied in the design of the Therapeutic Pocketbook.

Part II: The Genius of Boenninghausen

The Therapeutic Pocketbook is the fruit of Boenninghausen's discerning mind (he was a lawyer by profession) and his propensity for categorization (he was trained as a botanist). We're going to spend some time looking into several Boenninghausen insights which relate to his method of case analysis and which are completely grounded in the teachings of Hahnemann. We'll be examining these insights with emphasis on their incorporation into the design of the Pocketbook and how they influence its use. We'll be discussing them in the order in which they appear listed here.

1. Symptoms can be considered as consisting of three components: sensation, location and modality.
2. Proving and clinical patient symptoms are often incompletely reported.
3. In the recorded provings the most consistent symptom features are the modalities, the second most reliable features are the sensations and the least reliable (most variable) features are the locations.
4. The same sensations, and especially modalities, are frequently found in different locations and/or body systems. They are not bound to a single location or system and in fact they are the general characteristics.
5. The more consistent (characteristic) features of symptoms are transferable across locations and may be used to complete the missing details of less well described symptoms.
6. The uniqueness of a case is often found in its particular combination of otherwise common features.

(1) Symptoms can be considered as consisting of three components: sensation, location and modality.

In 1860³ Boenninghausen provided a long answer to a question concerning the (characteristic) value of symptoms in the homeopathic diagnosis (selection of the most similar remedy), wherein he identifies seven parameters which together provide the elements required in forming the ‘complete image of a disease’. These seven were reduced to four essential components: *complaint* (sensation), *location*, *modality*, *concomitant*. With this *tetralogy* Boenninghausen described the *complete case* (complete image of an illness). Unfortunately, even to the present day, this is erroneously taught as referring to the *complete symptom*, which however, Boenninghausen clearly defines as:

“...an enumeration of all the sensations and phenomena ...every symptom should be given clearly and completely... With respect to completeness in every case the exact location...so also...the aggravation or amelioration ... [are to be ascertained]” (Dimitriadis, 2002, p. 2)

I’ve already mentioned that Boenninghausen introduced the use of rubrics to summarize lengthy proving symptoms. This was a significant development in homeopathic literature as it allowed for the construction of manageable reportorial indexes. In Boenninghausen’s repertory this allowed for the reconstruction of complex symptoms through retrieving their separately indexed (in the form of rubrics) representative component features: the features of location, sensation and modality.

Synthesis and the Therapeutic Pocketbook each take different approaches to how they represent symptom features as rubrics. Synthesis tends to place each rubric within a chapter bearing the name of a specific location or bodily system. Rubrics within such chapters will contain descriptions of symptom sensations and, where such information is available, also the details of the conditions under which it is made worse or better. When a symptom is entered as a rubric in Synthesis an attempt is made to include as much supporting descriptive detail as possible and to fit this all into a single rubric to be situated within a specific repertory chapter bearing the name of a body location or system. For example

Head-pain-occiput-bending-head-backward-must bend head backward-drawing pain

³ Boenninghausen, Clemens. Lesser Writings, “A Contribution to the Judgment Concerning the Characteristic Value of Symptoms”.

The rubrics in the Therapeutic Pocketbook work in an entirely different manner. The descriptive detail contained in each complex materia medica symptom is abstracted and summarized in terms of its sensation, its location and its modality. This abridged description is then intentionally broken apart, to be recorded as multiple discrete rubrics each of which represents only a single portion – either sensation or location or modality – of the complete symptom. The separate single-purpose rubrics for symptom location, sensation, and modality are then dispersed throughout the appropriate repertory chapters set up for each type of rubric.

Let's take an example of a Belladonna symptom from Hahnemann's *Materia Medica Pura* which is converted into rubrics for Boenninghausen's *Systemic Alphabetic Repertory of Antipsoric Remedies*. The symptom as it appears in the proving reads as follows:

Sometimes complete loss of, sometimes merely diminished, vision, with enormously dilated and quite immovable pupils.

First the complex, context rich proving symptom has to be simplified and reduced to its essential descriptive component features of location, sensation and modality. These components are then represented as separate rubrics in the repertory with each being placed in the chapter that corresponds to that type of symptom component. Each of these rubrics is necessarily quite brief as it includes only a single facet of the original proving symptom. To retrieve this entire proving symptom complete with all of its original meaning you would need to select all three of the (component) rubrics used to record it in the repertory. Boenninghausen used this approach in his earlier SRA and SRN repertories as well as in the Therapeutic Pocketbook. The diagram on the following page illustrates how the essential features of this Belladonna symptom would be represented in the repertory. (Dimitriadis, p. 2)

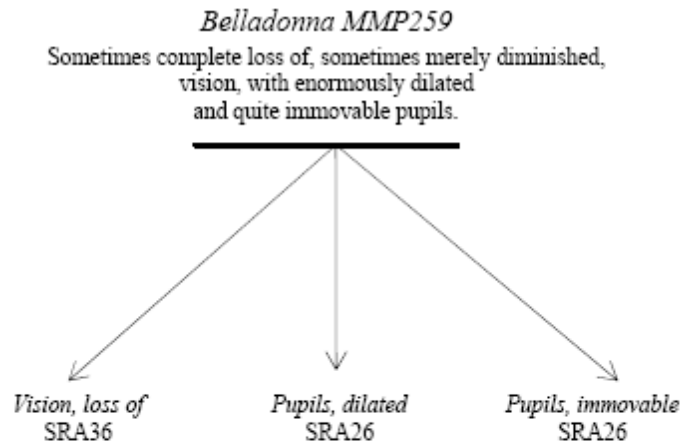

Figure 2
 The rubrication of symptoms for *repertography*.
 The component parts of this Belladonna symptom are shown separated
 (abstracted) and represented using rubrics (rubricated) within the SRA
 repertory, wherein they can be later re-combined.

From this Belladonna example you can see that using the Pocketbook is going to require that we alter our expectation about how much detailed description will be included in a rubric. Each Pocketbook rubric summarizes a single symptom feature in as few words as possible. However, the lack of specific detail in its rubrics doesn't make the Therapeutic Pocketbook a blunt or inaccurate instrument. We can obtain exact symptom descriptions by selecting rubrics from each of the chapters and re-combining them. Boenninghausen tells us the technique we are required to use with his repertory:

“Although each section may be considered by itself a complete whole, yet each one gives but one portion of a symptom, which can be completed only in one or several other parts. In toothache, for example, the seat of the pain is found in the second section, the kind of pain in the third, the aggravation or amelioration according to time or circumstances in the sixth, and whatever concomitant symptoms are necessary to complete the picture and select the remedy, are also to be found in the various sections.” (Roberts, p. 25)

An example may help to illustrate this technique. The Lycopodium symptom below is taken from Hahnemann's Chronic Diseases.

- Cramp in the calf, causing him to cry out at night, also by day, when sitting with bent knees.

In this symptom we have a location for the pain (calf), its sensation (cramping) and a modifying modality (sitting with knees bent) making it a complete symptom. In Synthesis all three essential features of the symptom are contained within a single rubric found in the **Extremities** chapter.

Extremities – Cramps – Legs – Calves – sitting – agg.

Repertorizing the same symptom using the Pocketbook requires three rubrics. Each comes from a different chapter in the repertory.

- (1) Parts of the body and organs – Lower limbs – Leg; lower – Calf**
- (2) Sensations and complaints – External parts of body and internal organs in general – cramps, cramp-like sensation – Muscles, in the**
- (3) Change of general state – Aggravation – sitting; while**

It's quite apparent from this example that the two repertories have very different approaches to how they represent symptoms. In Synthesis rubrics are found in chapters corresponding to body locations/systems with the exception being the Generals chapter. That is to say, in Synthesis rubrics are always associated with a location. Organizing rubrics this way binds them to their specific chapter location in the repertory. But in the Therapeutic Pocketbook a complete symptom – with a sensation, a location and a modality – has to be represented by at least three rubrics, each of which comes from a different chapter. Consequently a complete symptom cannot be said to be found within any single Pocketbook chapter at all.

Let's consider a second symptom. In this example you have a symptom almost identical to the first Lycopodium symptom. However instead of the pain being in the calf, this time

it is a pain in the abdomen; though it is still a cramping pain and is still worse when sitting. So the sensation and modality here are the same as in the first Lycopodium symptom with only the location being different. Again Synthesis records the second symptom with all the essential details as a single rubric. The second rubric is found in the **Abdomen** chapter.

Abdomen – Pain – Sitting agg. – cramping.

In Synthesis the same pain sensation with the same modality but in a different location necessitates entering a completely new rubric which is entered in a different chapter. The two nearly identical rubrics appear in two different chapters because in Synthesis every rubric is placed in the repertory according to its specific location in the body (the exception is the Generals chapter).

Using the Pocketbook to describe this second symptom we must select a new rubric for the new location, but seeing as the sensation and modality are identical to those in the first symptom we can represent them using the same Pocketbook rubrics we used earlier. The second symptom can be represented this way.

(1) Parts of the body and organs – Abdomen; internal – Abdomen in general

(2) Sensations and complaints – External parts of body and internal organs in general – cramps, cramp-like sensation – Muscles, in the

(3) Change of general state – Aggravation – sitting; while

In these two examples we can see how the Pocketbook's discrete rubrics for sensations, locations, and modalities can be used over and over again to represent different individual symptoms by means of their *unique configurations*.

There are a couple of immediate advantages designing a repertory this way. First, the repertory is much smaller due to its being able to represent individual unique symptoms through different combinations of the same stock of component rubrics (this is why the

Pocketbook has seven chapters while there are 40 in Synthesis). Second, it is easier to know where to find rubrics in the Pocketbook. All symptom locations are in one chapter, their sensations in another and their modalities in yet another.

To repertorize a symptom that includes a description of a sensation, location and modality you require at least three rubrics. A symptom with only location and sensation requires at least two rubrics. This arrangement is simple, direct and predictable. It doesn't contain those inconsistent arrangements in rubric organization, that often occur in Synthesis, such as **Extremities – Cramps – Legs – Calves – sitting – agg** (where the order is location-sensation-location-modality), and **Abdomen – Pain – Sitting agg. – cramping** (where now the order is location-sensation-modality-sensation). In Synthesis the order of words in a rubric determines its placement within the chapter. If you make a change to the order of descriptors in a rubric you also change the location of the rubric within the chapter. This can turn repertorization into a game of hide and seek. With the systematic arrangement used in the Pocketbook this problem does not occur; symptoms are very quickly and easily repertorized.

The third, and greatest, advantage to the design of the Pocketbook is that it can repertorize symptoms that fall short of being complete due to their lacking a description of either their location, their sensation or their modality.

(2) Proving and clinical patient symptoms are often incompletely reported.

In the course of doing my research I learned that the original provings of Boenninghausen's day⁴ contained numerous omissions. This was a disheartening revelation that only added to my sense of frustration regarding the repertory. However, after examining the origins of the Therapeutic Pocketbook I understood the reasons for these omissions and the challenge it posed for the early homeopaths who sought to bring order to their new science.

⁴ Hahnemann's *Materia Medica Pura* and the *Chronic Diseases*.

Boenninghausen had thoroughly studied Hahnemann's provings and in addition to this he had kept meticulous case records from his own practice. In both the recorded provings and his own case records he encountered the same problem: that of incomplete symptom reporting. In his original preface to the Pocketbook he comments on how the incomplete nature of symptoms recorded in the provings posed a hindrance to successful prescribing.

“If many symptoms are incomplete, either because the part of the body or the kind of sensation is not clearly indicated, or, what is most frequent, because the aggravations or ameliorations, according to time or circumstances, are omitted, the difficulties of correct apprehension and the judgment of the value of such symptoms for the necessities of curing are greatly increased, for the characteristic never shows itself in a single symptom, however complete it may be, since the individuality of the prover exercises an influence over the proving which easily misleads...” (Roberts, p. 24)

We can see the nature of incomplete proving symptom reporting if we do a search in Hahnemann's *Materia Medica Pura* and *The Chronic Diseases* for a well proven remedy such as *Arsenicum album*. A search using *Encyclopaedia Homeopathica* turns up 55 instances of the word “headache” in the proving of *Arsenicum*. A sampling of the recorded proving symptoms appears below:

- Melancholy, sad mood, after a meal, with headache
- Headache in the occiput.
- Headache, for several days, immediately relieved by applying cold water, but on removing it is much worse than before.
- Tension in the head; headache, as if stretched.
- Periodic headache.
- Headache of excessive severity.
- Semilateral headache.
- Headache above the left eye, very severe in the evening and at night.
- Pinching headache above the eyes, soon passing away.
- Throbbing headache in the forehead, just above the root of the nose.

You can see there is a lot of variation in the detail include in these proving symptoms. The first record includes mental/emotional accompanying symptoms as well as a context (after the meal). The second record contains no description of the pain but does include the location (occiput). The third record contains a lot of detail about a modality (applying cold water). The fourth record emphasizes a sensation (as if stretched), while the fifth

record describes a rather vague “periodic” headache. Notice that not one of these original recorded symptoms from the Arsenicum proving is complete – in terms of including a description of sensation, location and also modality – instead each entry seems to report *only part of a complete symptom*.

That the provings records were incomplete was a huge obstacle Boenninghausen had to overcome in creating his repertory. The problem this posed for successful prescribing was only made that much worse by a similar lack of descriptive detail in the symptoms reported by patients, as we read in the following two quotations:

“The Totality is an ideal not always to be realized. As a matter of fact, in practical experience, it is often impossible to complete every symptom, or even a large part of the symptoms. Patients have not observed, or cannot state all these points. They will give fragments; the location of a sensation which they cannot describe, or a sensation which they cannot locate; or they will give a sensation, properly located, but without being able, through ignorance, stupidity, failure to observe or forgetfulness, to state the conditions of time and circumstances under which it appeared. Sometimes no amount of questioning will succeed in bringing out the missing elements of some of the symptoms.” (Close)

“In examining a case, he gets what appears to the novice to be a heterogeneous lot of symptoms, or fragments of symptoms. Possibly there may not appear to be one complete symptom in the record. He will find a clearly expressed sensation in some part, but no condition of aggravation or amelioration. In another part, a clearly expressed condition of aggravation or amelioration, but an indefinite sensation; or perhaps the patient will simply give a condition of aggravation or amelioration which he refers simply to himself in general. He says, “I feel worse” under such and such conditions. In reality the patient is not expressing many symptoms, but only parts of a very few complete symptoms, which the homeopath must bring together and complete. The perceptible symptoms of disease are often broken up and scattered through the different parts of a patient’s organism. *The scattered parts must be found and brought together in harmonious relation according to the typical form.*” [Italics added]. (Roberts, p. 4)

Boenninghausen’s close examination of the provings had resulted in a remarkable insight and Roberts (in the second quotation - the italicized portion) refers to this when he charges us to re-establish the “typical form” of the case once more. Boenninghausen knew that the provers had been under the influence of a single pathogenic disease

disturbance, that of the homeopathic remedy. He reasoned that their incompletely described symptoms were fragmented glimpses of a single symptom complex belonging to the remedy they had taken. By similar logic, he inferred that the incompletely described symptoms reported by his patients were also due to a single disturbance, the natural disease disturbance in this instance; and that they too were being reported as *fragments of a single symptom complex*.

Perhaps an analogous example from the physics of light will help with this idea. When shining white light through a prism the light emerges on the other side as rainbow bands of separate colours. The prism seems to have broken the light apart somehow. Even more remarkable is that prisms made of different materials will break apart the light in different ways producing variations in the pattern of presence or absence of colour which is dependent on the material used in the prism. The situation in homeopathy is similar. The patient acts like a prism to the “whole light” of the remedy altering its symptom display from that which has been recorded in the provings. Each patient alters the display of the remedy in a different manner, shifting some symptoms of the display to other locations, allowing some sensations and modalities through while blocking others out altogether. The real art of homeopathy is to be able to identify the fully expressed symptom pattern of a remedy as recorded in the provings, from the incomplete and often fragmented display of emergent symptoms that is the result of each unique interaction between remedy and patient.

The Therapeutic Pocketbook’s design facilitates the identification of remedy symptom patterns through rubrics that each focus on a single symptom component. By means of these rubrics we can highlight the most consistent symptoms in a case even though they may be only partially described. When placed in juxtaposition on our repertory charts the Pocketbook rubrics allow us to see through the jumbled disarray of symptom fragments to the “typical form” of a remedy’s representative symptoms once again.

(3) In the recorded provings the most consistent symptom features are the modalities, the second most reliable features are the sensations and the least reliable (most variable) features are the locations.

Boenninghausen's in depth study of the provings resulted in his emphasizing the modalities of a remedy above its sensations and locations.

“Only with reference to aggravations and alleviations of symptoms according to time, position and circumstances the higher and the lower potencies ever remain the same, and this constant uniformity ought to urge Homoeopaths to study these momenta with particular industry, and to pay especial attention to the same when selecting a remedy.” (Boenninghausen, "The Value of High Potencies")

In his companion book to The Boenninghausen Repertory⁵, George Dimitriadis tells us that when symptom modalities are consistent and clearly defined in a case they reveal the “core” of the remedy homeopathic to the patient's sufferings:

“According to Boenninghausen's above observation, the range of symptoms a medicine is able to curatively remove in practice, whilst gradually expanding in proportion to their increased potentisation, nevertheless retained a semblance of continuity in their basic character, which could be implied from their defining qualities of location and sensation (complaint/sensation; signs & symptoms). In this way the completeness of a symptom could even be inferred and extended by analogy – and this proved a most fundamental advance in understanding the often incomplete fragments of our materia medica provings. But even more importantly, the modalities remained entirely unaltered, regardless of the potency used. In other words, the modalities, when clearly and completely defined, faithfully represented the constant character of a medicinal proving and of its therapeutic application – they revealed its unchanging core, and it is for this reason that modalities often provide the most decisive distinction to the homeopathic diagnosis. From this we can readily see that the location is (usually) subordinate to the complaint (nature of the signs & symptoms), which is in turn is subordinate to the modalities. This holds good to such an extent that (guided by experience) the higher order “momenta” can be used exclusive of the lower order in the determination of the homeopathic diagnosis – for example, in a case with modalities sufficiently distinguishing to enable the correct medicine selection, there is no need to consider the lower order location/complaint in the prescription when using TBR.[Therapeutic Pocketbook]” (Dimitriadis, 2004, p. 52)

⁵ Homeopathic Diagnosis: Hahnemann through Boenninghausen. Sydney, Australia. 2004

When our case includes symptoms that are well defined and consistent in their presentation we should make a point of including them in the analysis. Representing such symptoms in the Therapeutic Pocketbook will likely require using multiple rubrics – one for sensation, another for location and a third for modality. If we want to place additional emphasis on an important symptom we apply additional weighting to it in our repertorizing. This additional weighting must be applied equally to all the rubrics we have used representing the symptom in the Pocketbook.

We do not always need to think of repertorizing whole symptoms when using the Pocketbook. If our patient describes the sensation of a consistent symptom but cannot tell us if it has a modality or a particular location, we can repertorize the sensation alone. Similarly when our patient gives us a description of a modality but cannot provide much else we can, and should, repertorize the modality despite not having a clear description of where the symptom is or even what it feels like because modalities are more reliable as guides to finding the remedy.

Should our case have a recurring modality or sensation, one present in several of the symptoms, then this modality or sensation acquires additional importance becoming elevated to the status of a “genius” symptom in the case. Genius symptoms are placed at the head of the analysis as our prescription must include them. With the Pocketbook we can select a single rubric for the recurrent modality or sensation and add that to our analysis. The Pocketbook’s discrete rubrics for sensation, location and modality permit us to assign special importance to a “genius” modality or sensation by giving its rubric additional weighting. All those remedies having this modality or sensation will be brought forward in the analysis as a result. On studying the relevant materia medica of the foremost remedies appearing in our analysis, if we find a remedy with the same consistent modality or sensation (or even location) running through multiple symptoms of its proving, we may feel confident in considering that remedy further as the presence of this recurrent theme in both remedy and patient suggests a solid match.

(4) The same sensations, and especially modalities, are frequently found associated with different locations and/or body systems. They are not bound to a single location or system and in fact they are the general characteristics.

Boenninghausen recognized from his study of the provings and his own patient records that symptom modalities and symptom sensations were not confined to the particular location(s) in which they were reported and that, in fact, they were symptoms belonging to the whole patient and were especially important in selecting the remedy.

“From one point of view the indicated conditions of aggravation or amelioration have a far more significant relation to the totality of the case and to its single symptoms than is usually supposed; they are never confined exclusively to one or another symptom, but on the contrary, a correct choice of the suitable remedy depends very often chiefly upon them. In reality, then, they are the general characteristics.” (Roberts, p. 4)

The process of generalizing sensations and modalities bears some explaining and this might best be served through an example taken from the proving of Causticum. The modality in this example is “worse sitting”. Drawing from Hahnemann’s *Materia Medica Pura and Chronic Diseases* we can perform a search under the remedy Causticum for the word “sitting” to see how often this modality shows up. The search in EH reveals 37 occurrences of “sitting” some of which I’ve listed below:

- Frequent fits of choking on inspiring, as if some one was constricting the windpipe, so that it obstructed the breath, when sitting.
- Pressive, cramp-like pain in the sacrum and the renal region, when sitting.
- Sensation as from a bruise in the sacrum, when walking; going off when sitting.
- Stitches in the back, as from needles, when sitting down.
- The nates pain in sitting on them, as if from being beaten, or as if turgid.
- A drawing pressive pain in the hip, when sitting and when walking.
- Tearing in the hip-joint and down the whole limb, both sitting and walking.
- Feels as if paralyzed in the thighs, in sitting and in walking.
- Turgidity in the houghs in sitting, and when commencing to walk; better when continuing the walk.
- Tearing in the left tendo-Achillis, when sitting.
- Pain as from bruising, all over the body, especially in the arms, when sitting; going off when at work and in the open air.
- Sleepiness, especially while sitting, but also while walking.

- Frequent urging to urinate without discharge; then, when sitting, an involuntary discharge.
- Loud rumbling in the abdomen, when sitting, as if from emptiness.
- Momentary vertigo, while sitting, as if the was about to stagger

In this short list you can see that an aggravation associated with sitting is a recurring feature in the remedy Causticum and that it is not specific to any one location or associated with a particular sensation only. This is exactly why Boenninghausen generalized it. He knew from his study of the provings that this was repeatedly true of remedy modalities and that it was also true of sensations, though to a lesser extent.

“Thus the statement that the Pulsatilla case is ‘worse in a close or warm room’ is a generalization drawn from the observation of particular symptoms in numerous cases, both in provings and clinically. The same is true of nearly every condition of aggravation and amelioration contained in Boenninghausen's Repertory, the greatest masterpiece of analysis comparison and generalization in our literature. Experience has shown that most of these "conditions" or modalities of Boenninghausen are general in their relations. The attempt to limit the application of the modality to the particular symptoms with which they were first observed has not led to success in prescribing. Boenninghausen did his work well, and he followed strictly the inductive method. Of these modalities he wrote: "All of these indications are so trustworthy, and have been verified by such manifold experiences, that hardly any others can equal them in rank-to say nothing of surpassing them. But the most valuable fact respecting them is this: That this characteristic is not confined to one or another symptom, but like a red thread it runs through all the morbid symptoms of a given remedy, which are associated with any kind of pain whatever, or even with a sensation of discomfort, and hence it is available for both internal and external symptoms of the most varied character." In other words, they are general characteristics deduced by a critical study of particulars and verified in practice.” (Close)

Boenninghausen recorded these characteristic modalities and sensations as rubrics in his Therapeutic Pocketbook in a way that allowed them to become “generals” able to be applied to any location whatsoever. As we’ve already seen, he achieved this through extricating the symptom elements of sensation and modality from their original context (the locations in which they were reported) and recording them in the Pocketbook as standalone rubrics that were placed in designated chapters for each type of component.

To see how these rubrics can be used to represent actual proving symptoms let's take a look at a few symptoms from the proving of Bryonia.⁶ We see that Bryonia has a recurring modality of being worse from becoming heated or warmed:

- Toothache on taking something warm into the mouth.
- While eating there occurs a tearing shooting toothache (that extends down into the cervical muscles), which is especially aggravated by warmth.
- Sore throat: dry and raw in the throat during empty swallowing; on drinking this sensation goes off for a short time, but soon recurs; it is worst in the warm room.
- When he comes from the open air into the warm room he has a feeling as if vapour were in the windpipe, which compels him to cough; he feels as if he could not breathe in air enough (aft. 2 h.).
- Fine shooting in the wrist, when the hand becomes warm and when at rest; but it does not go off by movement.
- On a slight mental emotion (on laughing) there suddenly occurs a shooting (itching) burning all over the body as if he had been whipped with nettles or had nettle rash, though nothing is to be seen on the skin; this burning came on afterwards by merely thinking of it, or when he got heated.

In the Therapeutic Pocketbook this recurring theme is represented by a single rubric **Change of general state – aggravation – heated, overheating; from becoming** and Bryonia is listed there as a 4. By recording this modality of Bryonia as a separate rubric, free to be applied in combination with any location and/or sensation rubric, the Pocketbook mirrors the pervasiveness of the modality as it is found in the Bryonia proving. It is this unique feature of the Pocketbook that allows us to apply Boenninghausen's insight regarding symptom generalization at the point in time where we are repertorizing the case.

We can use this rubric in combination with other rubrics in the Pocketbook to accurately represent any of the symptoms from the list above without loss of meaning. For example, to repertorize the first symptom we would use two rubrics: **Parts of the body and organs – teeth – toothache in general** plus **Change of general state – aggravation – heated, overheating; from becoming**. To repertorize the second symptom we would need four rubrics: **Parts of the body and organs – teeth – toothache in general**, add the modality of being worse from eating **Change of general state – aggravation – eating**, then **Sensations and complaints – external parts of the body and organs – tearing (drawing)** for the nature of the pain, and once

⁶ Hahnemann, S., *Materia Medica Pura*

again for the modality worse warmth we use **Change of general state – aggravation – heated, overheating; from becoming.**

Constantine Hering and Ernest Farrington were two notable critics of Boenninghausen's repertory design on the grounds that information was either being distorted or lost when a locally specific modality or sensation was removed from its particular location and treated like a general symptom. However, Boenninghausen did not suggest that the materia medica should be treated this way, only the repertory. His *Characteristics*⁷ does not contain symptoms created by analogy and remains a faithful account of remedy symptoms recorded from the provings and from clinical experience. (Taylor, Taking the Case, "Symptoms by Analogy") Repertory and materia medica both represent the accumulated knowledge of our remedies, albeit in different ways, and each has their rightful place in analyzing the case. However, the final authority must always belong to the materia medica.

(5) The more consistent (characteristic) features of symptoms are transferable across locations and may be used to complete the missing details of less well described symptoms.

“Bönninghausen observed that individual symptoms recorded in our pure materia medica are often only fragmentary, and that their completion could be inferred (by analogy) from related or associated symptoms in the provings. Bönninghausen was able to identify each and every characteristic feature of the remedies he studied, confirmed through his extensive practice, and increasingly focused on gathering only such characteristics during the process of case-taking.”
(Dimitriadis, 2002, p. 3)

The symptoms in the following list are taken from the proving of Conium appearing in Hahnemann's Chronic Diseases and his *Materia Medica Pura*. They refer to the sensation of vertigo and were reported by several provers:

- Dizziness and whirling in the head for two days.
- Very dizzy while walking.

⁷ Boger, C.M., Boenninghausen's Characteristics

- Intoxication.
- The least spirituous liquor intoxicates him.
- Even a mixture of water and wine affects his head.
- Constant stupefaction of the head, with continuous desire to sleep.
- Reeling.
- Vertigo, whirling around when he rises from his seat.
- Vertigo, after stooping, when raising up again, as if the head would burst.
- Vertigo, worse lying down, as if the bed were whirling around in a circle.
- Vertigo, early on rising from the bed.
- Vertigo on going down stairs; she had to hold on to something, and for a moment she did not know where she was.
- Vertigo which fatigues the head.
- Vertigo, so that everything seems to whirl around.

A quick look over the list reveals that while some of the entries contain very little detail, others describe a symptom with great specificity. Boenninghausen would have read a similar list of vertigo symptoms as he studied the materia medica of his day. He was able to retain in view that despite the variation in the amount of detail reported by the provers, all of their symptoms had to be due to the same cause; the remedy they had taken to the point of proving it. Boenninghausen knew that this variation in recorded symptoms could be attributed to the individuality of the provers and reasoned that the incompleteness of their proving symptoms could be rectified through the use of analogy. With reference to the list of Conium vertigo symptoms above, Dimitriadis explains the process of completing symptoms by analogy:

“It can be seen that these symptoms ...all refer to a single type of (vertiginous) complaint and that some offer no qualification..., whilst others provide quite a striking description..., or decided modality... Yet, to repeat the point, there is no doubt that all these symptoms are the effects of a single remedy, a *single pathogeny*, each symptom revealing the same complaint with a greater or lesser degree of definition (completeness) as observed in a number of subjects during proving. With this in mind let us now consider the above group of symptoms as related pieces of a single symptom, which would then look something like this:

Intoxicated feeling in the head, with vertigo, to the point of reeling; as if everything is reeling around; aggravated by: the least alcohol, whilst lying in bed, whilst walking, on rising (from bed, from sitting, after stooping);

with momentary disorientation whilst descending the stairs, she has to hold on to something.

This composite picture of vertigo produced by Conium is thus more defined, ‘completed’ by analogy (i.e., by transferring and combining the qualifying characteristics of related symptom fragments), with a resultant good description of the complaint, and its clear modalities.” (Dimitriadis, 2004, p. 19)

Symptoms completed by analogy must still be broken down into their abridged and representative components to be entered into the Pocketbook. Boenninghausen’s brilliance was to catalogue these symptom features using multiple rubrics, each of which captured an essential symptom component (location, sensation, modality), such that they could be recombined to restore the full meaning of the proving symptom once again. Keep in mind that this completed Conium symptom is a “composite” symptom, constructed from the combined partial descriptions given by several provers. We might be represent this symptom in the Pocketbook using eight rubrics:

- 1. Mind and Sensorium - Confusion [cloudiness, etc.] – confusion of mind, fogginess**
- 2. Mind and Sensorium - Confusion [cloudiness, etc.] - stupefaction**
- 3. Mind and Sensorium - Confusion [cloudiness, etc.] - vertigo**
- 4. Change of general state - Aggravation - rising from stooping**
- 5. Change of general state- Aggravation – rising from bed – when**
- 6. Change of general state - Aggravation – rising from sitting - when**
- 7. Change of general state - Aggravation - food and drinks; from partaking certain - spirituous liquors in general [alcoholic drinks]**
- 8. Change of general state - Aggravation - lying; while - bed; in**

As each individual rubric captures only a single component of the completed symptom, recreating the entire composite vertigo symptom would require selecting all eight rubrics.

Investigation window for remedies

125% Display Strategy Restrict to

1. Therapeutic Pocketbook

- Mind and Sensorium - Confusion [cloudiness, etc.] - confusion of mind, fogginess (68) 1
- Mind and Sensorium - Confusion [cloudiness, etc.] - stupefaction (66) 1
- Mind and Sensorium - Confusion [cloudiness, etc.] - vertigo (117) 1
- Change of general state - Aggravation - rising from stooping (67) 1
- Change of general state - Aggravation - rising from bed - when (76) 1
- Change of general state - Aggravation - rising from sitting - when (68) 1
- Change of general state - Aggravation - food and drinks; from partaking certain - spirituous liquors in general [alcoholic drinks] (49) 1
- Change of general state - Aggravation - lying, while - bed; in (122) 1

	thust.	bell.	nux-v.	puls.	verat.	con.	lyc.	nat-m.	acon.	cocc.	stram.	bov.	sep.	als.	chin.	caust.	bry.	phos.	calc.	ph-ac.	laur.	sil.	sulph.	cham.	rhod.	caps.	dic	
1	8	8	8	8	8	8	8	8	8	8	8	8	8	8	8	8	7	7	7	7	7	7	7	7	7	7	7	7
27	26	25	25	23	22	22	21	18	18	18	16	16	15	15	13	22	20	20	18	18	17	16	16	15	13			
1.	3	4	3	3	3	3	2	2	1	3	3	2	2	1	1	2	4	2	3	3	4	3	1	2	2	2	2	1
2.	4	4	3	3	4	3	1	3	1	1	4	3	1	3	1	1	3	3	3	4	3	2	2	2	2	1	3	
3.	4	4	4	3	3	3	2	3	2	3	2	3	1	1	3	3	4	4	3	3	3	3	2	2	2	1	3	
4.	4	4	4	3	2	3	3	3	4	3	1	2	1	3	2	1	4	3	-	1	2	-	4	3	-	2	3	
5.	3	3	3	2	2	4	3	3	3	4	2	2	2	1	2	1	4	3	3	3	-	3	-	3	3	3	1	
6.	4	3	3	4	3	4	4	3	3	2	1	1	3	1	3	3	3	4	2	4	3	2	3	2	1	4	1	
7.	3	3	4	3	3	1	3	3	1	2	3	2	1	3	3	1	-	-	3	-	1	3	1	-	3	-	-	
8.	2	1	1	4	3	1	4	1	2	1	1	2	3	2	2	1	1	3	2	2	2	2	3	2	3	2	1	

125 remedies / 8 symptoms Sum of symptoms, sort: degree No restriction All remedies considered

Fortunately, when using the Pocketbook, we don't need all the details of the fully complete vertigo symptom to be present in order to once again find Conium (listed 6th place above). Given any part of its full symptom description, we could match that partial description to one, or more, of the eight rubrics we've used to represent the completed vertigo symptom and still bring Conium into our analysis. Consider a situation with a patient who told us that he had vertigo accompanied by confusion. We could capture that symptom, and Conium, using rubrics 1 and 3 from the chart above. With a patient who told us that she had vertigo with a feeling like being intoxicated, we could represent this using rubric 2 and 3 on the chart, and once again find Conium. Should a patient tell us that his vertigo was worse rising from bed, we would use rubrics 3 and 5, and once again find Conium.

The Therapeutic Pocketbook's design is superbly practical. Boenninghausen enables us to find a remedy again given a partial description corresponding to any one or more of the components of its (fully completed) symptom. Though we may have a symptom that is

only incompletely described we can still repertorize the symptom fragment and bring the remedy from which it originated into our analysis. By means of this ingenious design the Pocketbook overcomes two immense obstacles to homeopathic prescribing. First, by recording sensations and modalities as independent rubrics in separate chapters, it permits us to transfer the consistent and clinically verified characteristic components of remedies in order to complete the missing details of the provings. Secondly, it enables us to repertorize incompletely described symptoms obtained while taking the case. In this way it overcomes the gaps in symptoms reported by patients.

A word of caution is needed at this point. With the Pocketbook our freedom to associate rubrics in any combination whatsoever is not without its limits. That limit is reached at the point of *contradiction* with the materia medica. (Dimitriadis, 2007) A classic example of such a contradiction is the headache of Arsenicum. Arsenicum is known to be better from heat generally, yet it has a headache that is ameliorated by cold water⁸ and also by cold air⁹. Now in the Therapeutic Pocketbook we can take the rubric **Change of general state-amelioration-warmth in general; from** to represent Arsenicum's well established amelioration from warmth. Add the rubric **Parts of the body and organs – internal head – general in** to represent the location of a head pain; then add a rubric to represent a burning sensation **Sensations and complaints- external parts of body and internal organs in general-burning-internal organs; of** then include another rubric for a bursting sensation **Sensations and complaints – external parts of body and internal organs in general – bursting (dragging, pressing asunder); pain as if** and finally a rubric for flushing of the face **Parts of the body and organs-face-color-red**. With this combination of five rubrics we've created a headache from the repertory that is burning and bursting in nature, accompanied by a flushed face and better from warmth. If we place these rubrics on an analysis chart we see that Arsenicum appears in each rubric we've used for this headache. Given this remedy's well known amelioration from warmth this shouldn't come as much of a surprise.

⁸ Hahnemann, Chronic Diseases

⁹ Allen, T.F., Encyclopedia of Pure Materia Medica

Investigation window for remedies

125 %

Display Strategy Restrict to

1. Therapeutic Pocketbook

1. Sensations and complaints - External parts of body and internal organs in general - burning - Internal organs; of (106) 1
2. Sensations and complaints - External parts of body and internal organs in general - bursting (dragging, pressing asunder), pain as if (101) 1
3. Parts of the body and organs - Face - color - red (121) 1
4. Parts of the body and organs - Internal head - General; in (123) 1
5. Change of general state - Amelioration - warmth in general; from (90) 1

	bell.	nux-v.	acon.	bry.	ign.	sabad.	caust.	tan-b.	sep.	sil.	chin.	kali-c.	merc.	phos.	spig.	calc.	hep.	hyos.	thus-t.	ars.	cocc.	dulc.	sulph.	am-c.	caps.	carb-v.	lyc.	mez.
1.	4	4	4	4	2	4	3	3	4	3	3	2	4	4	2	3	2	1	3	3	2	3	4	2	1	3	3	3
2.	4	1	2	4	4	1	4	4	4	3	2	3	2	2	4	4	1	2	1	1	1	1	1	1	3	2	1	2
3.	4	4	4	4	3	3	2	3	2	2	4	2	3	2	3	2	3	4	3	2	3	2	3	2	2	1	3	1
4.	3	4	3	2	4	4	2	2	3	4	3	3	4	4	3	3	3	3	2	2	3	2	3	3	2	3	3	3
5.	3	4	3	2	3	4	4	3	2	3	2	4	1	2	2	1	4	3	4	4	3	4	1	3	3	2	1	2

125 remedies / 5 symptoms Sum of symptoms, sort: degree No restriction All remedies considered

However, when we go to the materia medica we find the following recorded by Kent for Arsenicum:

- When the headache is of a congestive character, with the sensation of heat and burning inside the head, and there is a feeling as if the head would burst, and the face is flushed and hot, that headache is better from cold applications and in the cool open air. (Kent)

Using the Pocketbook's unrestricted potential for rubric combining we've managed to create a symptom for Arsenicum that is not confirmed in its materia medica. Moreover, in Kent's Lectures on Homeopathic Materia Medica we read of an Arsenicum headache with a modality *opposite* to the modality we have associated with this headache.

Whenever our reading turns up something contradictory like this we should strongly question what is being suggested by the repertory. While modalities and sensations are features of the patient as a whole and may be transferred from one location to another, they must always give ground to *locally specific* modalities whenever they are present.

(6) The uniqueness of a case is often found in its particular combination of otherwise common features.

In Aphorism 153 Hahnemann tells us which symptoms we are to focus our attention on in order to obtain the most useful elements of the case for our prescription.¹⁰ Historically there has been much debate over the meaning and implementation of this aphorism. One word, the word characteristic, has come under a special scrutiny having been subject to considerable interpretation.

In paragraph 153 of The Organon, Hahnemann says that in comparing the collective symptoms of the natural disease with drug symptoms for the purpose of finding the specific curative remedy, "the more striking, singular, uncommon and peculiar (characteristic) signs and symptoms of the case are chiefly and almost solely to be kept in view... This seems a sufficiently clear description of what Hahnemann meant by "characteristic" symptoms; and yet the term has been the subject of much discussion and many have differed as to what constitutes a "characteristic." Confusion arose and still exists through the inability on the part of many to reconcile the teaching of this paragraph with the apparently conflicting doctrine of The Totality of the Symptoms as the only basis of a true homoeopathic prescription. (Close)

The quotation above raises an important question: Is there really a conflict between prescribing on the totality of symptoms and prescribing on the characteristic symptoms? To answer this question we need to take a closer look at this word "characteristic".

According to Dimitriadis "characteristic", as it appears parenthesized in this aphorism, has been taken to apply to the word immediately preceding it. That word is the word "peculiar". Dimitriadis disagrees with this interpretation. In his opinion the term "characteristic", as it was used in the time of Hahnemann, meant "consistent". The

¹⁰ In this search for a homoeopathic specific remedy, that is to say, in this comparison of the collective symptoms of the natural disease with the list of symptoms of known medicines, in order to find among these an artificial morbific agent corresponding by similarity to the disease to be cured, the more striking, singular, uncommon and peculiar (characteristic) signs and symptoms of the case of disease are chiefly and most solely to be kept in view; for it is more particularly these that very similar ones in the list of symptoms of the selected medicine must correspond to, in order to constitute it the most suitable for effecting the cure. The more general and undefined symptoms: loss of appetite, headache, debility, restless sleep, discomfort, and so forth, demand but little attention when of that vague and indefinite character, if they cannot be more accurately described, as symptoms of such a general nature are observed in almost every disease and from almost every drug. (Organon of the Medical Art, Hahnemann, S., Dudgeon/Boericke translation of the 6th edition)

following quote is taken from an extensive footnote in which Dimitriadis discusses the interpretation of aphorism 153:

“The paragraph [aphorism 153], has unfortunately, been poorly worded, since it implies that the parenthesized ‘(characteristic)’ refers to the word immediately preceding it [peculiar], ...but this is not possible, since, as we have shown earlier, the term characteristic does not mean singular... but consistent. Therefore, and it has taken a long time for us to realise the misleading composition of this paragraph (when rendered into English), Hahnemann’s addition of ‘(characteristic)’ refers to the whole series of preceding descriptors...which, he reminds us, *must also be characteristic (consistent)*” [Italics added]. (Dimitriadis, 2004, p. 26)

Dimitriadis’ interpretation of the parenthesized “characteristic” to mean consistent makes a significant difference to the interpretation of aphorism 153. Two other words need to be clarified in order to fully appreciate the change in meaning. Dimitriadis takes issue with interpreting the word “peculiar” to mean strange, odd or unusual. He maintains that this is a decidedly modern interpretation and one not applicable to the word’s usage in the time of Hahnemann. In Hahnemann’s time peculiar would have had the meaning of something *belonging to one or singular*. (Dimitriadis, 2004, p. 27) An example of this earlier usage of the word is the sentence “A hot, dry climate is peculiar to Arizona.” where here peculiar carries the meaning of distinctive of, or specific to, someplace or something. The word “singular” is even more emphatic in that it carries the additional meaning of something being notable or extraordinary. If we go back to Aphorism 153 now, replacing “singular” with “**notable**”, and “peculiar” with “**distinctive**”, we arrive at a reading with a substantially different slant:

In the search for a homeopathically specific remedy, that is, in the comparison of the complex of the natural disease's signs with the symptom sets of the available medicines (in order to find among them an artificial disease potency that corresponds in similarity to the malady to be cured) the more striking, **notable**, uncommon, and **distinctive**, (*consistent*) signs and symptoms of the disease case are to be especially and almost solely kept in view. These, above all, must correspond to very similar ones in the symptom set of the medicine sought if it is to be the most fitting one for cure. The more common and indeterminate symptoms (lack of appetite, headache, lassitude, restless sleep, discomfort, etc.) are to be seen with almost every disease and medicine and thus deserve little attention unless they are more closely characterized.

This interpretation of aphorism 153 lays emphasis on the *distinctive* and *consistent* symptoms in each case of illness, a different interpretation from that of Kent who emphasized the “strange, rare and peculiar” features of disease placing the SRP at the head of his famous hierarchy of symptoms. I would suggest that Dimitriadis’ interpretation of Aphorism 153 is closer to Hahnemann’s original intent as we find it expressed in his earlier writings:

The chief signs are those symptoms that are most constant, most striking, and most annoying to the patient. The physician marks them down as the strongest, the principal features of the picture. (Hahnemann, "The Medicine of Experience")

On Remedy Keynotes

Homeopaths have long sought to make the task of finding the simillimum less arduous. Some set about this by organizing our materia medica in ways that facilitated its learning. One such approach was Guernsey’s “Keynote”:

“It [the keynote] is only meant to state some strong characteristic symptom, which will often be found the governing symptom, and on referring to the Symptomen Codex, all the others will surely be there if this one is. There must be a head to every thing; so in symptomatology, if the most interior or peculiar, or key-note is discernible, it will be found that all the other symptoms of the case will be also found under that remedy that gives existence to this peculiar one, if that remedy is well proven. (Guernsey)

Guernsey intended that the term “keynote” refer to those symptoms within a remedy’s totality that most strongly declared its individuality. For this the symptom had to possess two qualities. First, it had to be a prominent symptom, consistently present in the provings and clinical picture of the remedy; and secondly, it had to be a somewhat uncommon symptom, one not shared by many remedies. Now in our examination of Aphorism 153 we found *both* consistency and distinctiveness are required for a symptom to be most useful in homeopathic prescribing. These are the very qualities found in Guernsey’s keynotes. This realization did not escape the attention of Stuart Close who

applied himself to reconciling these seemingly divergent view points in the ongoing controversy generated by Aphorism 153:

“There is certainly that in every case of illness which pre-eminently characterizes that case, or causes it to differ from every other. So in the remedy to be selected, there is and must be a peculiar combination of symptoms, a characteristic or keynote...

If it is understood that the "keynote" to a case may and often does exist in, or consist of, a "peculiar combination," as Dr. Guernsey puts it, and that it is not merely some peculiar, single, possibly incomplete symptom which the tyro is always mistakenly looking for, the subject is cleared of part of its obscurity... (Close)

The remedy keynote expresses an essential and prominent aspect of its remedy and may serve as a quick guide to a small group of remedies sharing a centrally important and highly characterizing feature. (Taylor, Taking the Case: "H.N. Guernsey and the Concept of Keynotes") When present in a case of disease, the keynote can potentially indicate the curative remedy *provided* the other symptoms of the disease totality also exist in the symptomatology of the remedy. The mere presence of a “keynote” symptom, though it may be strongly suggestive of a remedy, does not guarantee similitude.

For example, consider a patient whose chief complaint is a rheumatoid arthritic joint pain in the shoulder, stitching and pressing in nature and better in wet weather. The location, the sensation and the modality of the joint pain suggest several possible remedies. If we were considering remedies with keynotes matching the shoulder pain we would be thinking of remedies like Bryonia (stitching rheumatic pains), Causticum (amelioration in wet weather), Rhododendron (rheumatic, gouty pains) and Nux vomica (amelioration in wet weather). If the patient also was distinctly chilly when the joint pain was at its worst (concomitant symptom #1) we might look at remedies with this keynote, such as Pulsatilla, Arsenicum and Causticum again. If along with this the patient was extremely thirsty and for large quantities (concomitant symptom #2) then we would think of Bryonia, Arsenicum, Sulphur, and Phosphorus as these remedies have this keynote symptom.

Investigation window for remedies

125% Display Strategy Restrict to

	bry.	sulph.	caust.	nat-m.	als.	acon.	phos.	rhod.	rhust.	calc.	kali-c.	merc.	puls.
1	2	3	4	5	6	7	8	9	10	11	12	13	
5	4	4	4	4	4	3	3	3	3	3	3	3	
12	10	9	8	7	6	7	7	7	6	6	6	6	
1. EXTREMITIES - PAIN - Joints - stitching pain (96) 1	3	3	2	2	-	1	2	2	3	3	3	3	2
2. GENERALS - WEATHER - wet weather - amel. (47) 1	3	1	3	-	1	2	-	2	-	-	-	-	-
3. EXTREMITIES - PAIN - Shoulders - rheumatic (128) 1	2	3	2	2	1	1	2	3	3	2	2	2	2
4. STOMACH - THIRST - large quantities; for (77) 1	3	3	-	3	3	2	3	-	-	-	-	1	-
5. CHILL - CHILLINESS - pain; with (23) 1	1	-	2	1	2	-	-	-	1	1	1	-	2

248 remedies / 5 symptoms | Sum of symptoms, sort: degree | No restriction | All remedies considered

Let's look at the remedies we've considered on the basis of their "keynotes": Sulphur fails to cover chilliness with the pain; Causticum does not match the thirst for large quantities; even Rhododendron, which matches the nature of the shoulder pain so well, completely fails to cover the two concomitant symptoms that together define the case; while Pulsatilla, with its keynote of chilliness with the pains, appears in thirteenth place in the analysis. Each of these four remedies has one or more "keynotes" matching part of the case yet not one of the four covers the totality of symptoms. Only Bryonia covers the stitching pains, rheumatic pains and thirst for large quantities while also being in the rubric for chilliness during the pains. Though this last symptom is not a keynote of Bryonia it is a *defining* feature of the case and so it must be included in the symptom expression of the prescription. Reviewing the symptoms of this case we see that not one of them, on its own, is at all strange, or rare, or peculiar. Not even the "keynote" symptoms. It is their occurrence *as a totality* displayed in a single patient which is most defining, distinctive and remarkable, and which is met by one remedy alone.

In this discussion of Aphorism 153 we've seen that illness and remedy are individualized by their consistent and distinctive symptoms. For our prescription to be well chosen similitude must exist *here* between these unique sets of symptoms.

Dr. P. P. Wells says: "Characteristic symptoms are those which individualize both the disease and the drug. That which distinguishes the individual case of disease to be treated from other members of its class is to find its resemblance among those effects of the drug which distinguish it from other drugs. This is what we mean when we say that with these the law of cure has chiefly to do. *When we say 'like cures like' this is the 'like' we mean.*" (Italics added). (Close)

Contemporary homeopathic scholars are developing a modern language to express the meaning and directives of Aphorism 153. Dr. Joe Kellerstein¹¹ refers to homeopathic diagnosis as a process of "pattern matching". (Kellerstein) In our analysis of the case we are to bring the characteristic symptoms to the foreground while relegating the indistinct and common features of the patient's pathology to the background.

We are looking for symptoms that are so well described or so unique or so peculiar that only a small group, or perhaps even one remedy, has ever been recorded as curing that symptom. When we have in our case a good number...of these very characteristic symptoms we have a small nucleus of symptoms called a genius, or the most characteristic symptoms in the case. The genius of the case are the small group of most characterizing symptoms, most useful symptoms in pointing to one and only one remedy. And the genius is what must most closely correspond to the genius of the corresponding remedy. (Kellerstein, "Treating Mental and Emotional Disorders")

In this foreground symptom display it is "the 'concomitance' or form in which symptoms are grouped" (Close) that reveals the characteristic features of the illness and its defining individuality. When we repertorize these central symptoms we delineate the fundamental pattern informing the genius of the case. The Pocketbook displays this for us through the rubrics we select, and by means of matching patient symptom pattern to remedy symptom pattern, it reveals those remedies most homeopathic to this genius.

¹¹ Year III Clinical supervisor and lecturer at the Toronto School of Homeopathic Medicine

Part III: The role of the Repertory

“We should expect our Materia Medica to be a careful compilation of the pure and clinical symptomatology of our remedies. Various texts offer a range of emphasis from principally clinical offerings, to purely pathogenetic (proving) symptomatology, to mixes of these; and range from comprehensive treatises to concise keynote/confirmatory symptom listings. . . . The Repertory, on the other hand, does not contain a definitive description of individual remedies, but is expected to serve as a guide to recognizing the simillimum for a case. As such, its greatest potential for error is in exclusion - missing the simillimum for the case at hand in our analysis. With reference to the Materia Medica and seasoned wisdom remaining the final gold-standards in remedy selection, we can tolerate the Repertory suggesting a few extra remedies in our analyses - particularly when these errors of inclusion serve to avoid missing a good remedy suggestion due to an error of exclusion.” (Taylor, Taking the Case, "Symptoms by Analogy")

Rubrics in the Therapeutic Pocketbook

A rubric is a kind of encapsulation or summary of the materia medica. In some respects it's like a database search in that it retrieves lists of remedy names based on brief key-word descriptions of symptoms. The rubrics in Synthesis and the Pocketbook are designed differently when it comes to performing this function of retrieving. I'll be using Encyclopaedia Homeopathica (EH) to perform several searches using symptom descriptions in order to demonstrate the difference between the rubric designs of these two repertories. First I'll be using symptom descriptions arranged to perform like a Synthesis rubric to show how that repertory's rubrics encapsulate the materia medica. Then I'll use the same words arranged like the standalone rubrics found in the Therapeutic Pocketbook to show how that repertory represents the materia medica. I'd like to take a simple symptom, such as a tearing/drawing pain in the knees, to illustrate this.

Let's begin with an EH search set up in the manner of a Synthesis rubric. I can use EH to search for the word “knees” and also for “tearing” and “drawing”. I'll enter these words in the same line in the search parameters so that EH will only show me remedies where

all these words appear in the same sentence. The results from this first EH search are listed below.¹²

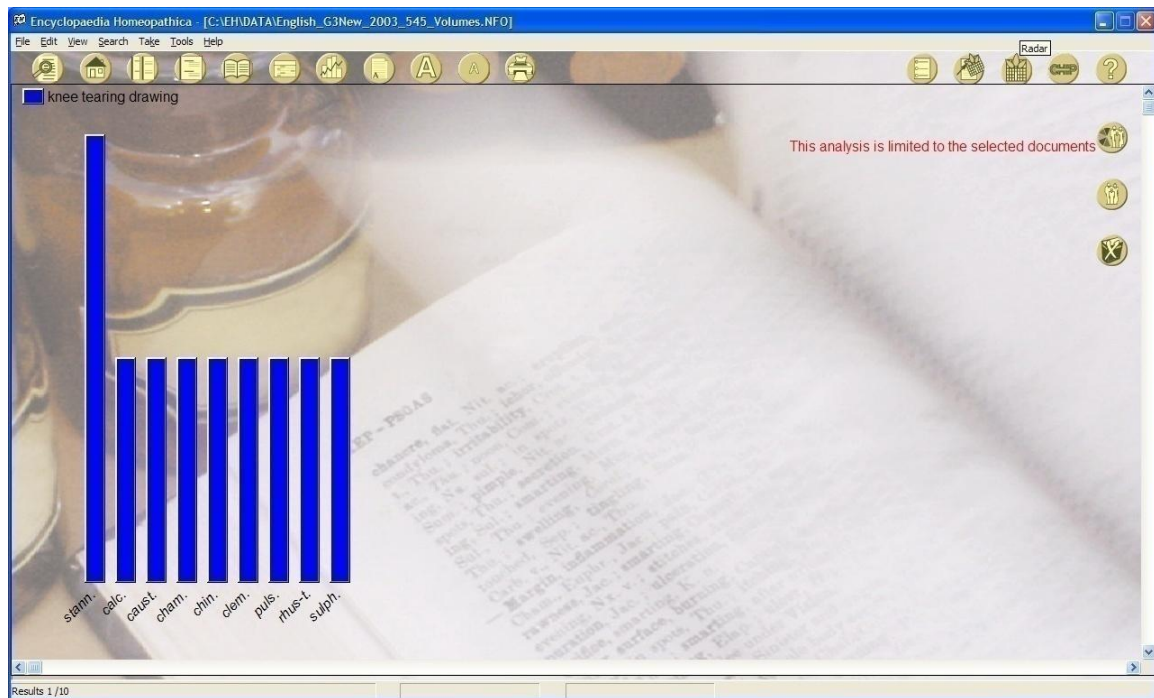

For a remedy to appear in this search we must be able to find occurrences of the word “knees” and also occurrences of “tearing” and ”drawing” pains within the same symptom. This search is equivalent to using the Synthesis rubric **Extremities-pain-knees-tearing pain-drawing pain**, where in order for a remedy to appear in this rubric it must have symptoms located in the “knees” that are also “tearing” and “drawing” in sensation. Six remedies appear in this Synthesis rubric.

The next EH search demonstrates the Therapeutic Pocketbook approach to this same symptom. We will again use the words “knees” and “tearing” and “drawing” but this time we’ll enter “knees” on one line and “tearing” with the synonym “drawing” on another line. Splitting up the location of the symptom and the sensation of the symptom this way will actually result in two completely separate searches. The results from the search set up this way appear on the following page.

¹² The EH searches that follow are limited to Hahnemann’s Materia Medica Pura and Chronic Diseases in order to justly compare the rubric performance of Synthesis to that of the Therapeutic Pocketbook.

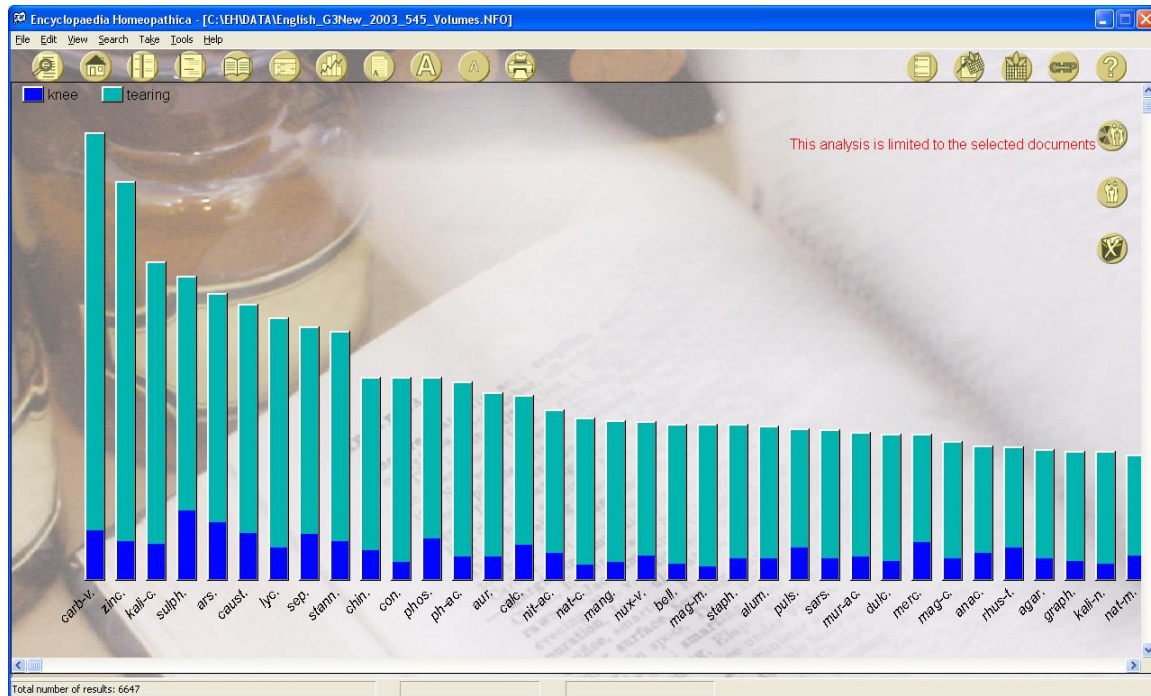

The EH search set up this way looks for symptoms involving the “knee” (indicated with blue bars) and then looks for symptoms involving “tearing”/“drawing” sensations (indicated with teal bars). In the search results display, there will be remedies listed with only results for “knee” symptoms (the blue bars) while other remedies will have only results for “tearing/drawing” symptoms (the teal bars). The remedies we’re interested in are the ones having blue and teal coloured results as this means they have symptoms associated with the “knee” and also symptoms with “tearing”/“drawing” sensations. The search set up this way finds 103 remedies.

The Therapeutic Pocketbook’s two rubrics – **Parts of the body and organs-lower limbs-joints-knees** and **Sensations and complaints-external parts of body and internal organs in general-tearing(drawing)-pressing-Joints;** in the approach this tearing/drawing knee symptom in the same manner as the two separate search lists in the chart above. The first rubric will give us a listing of remedies with symptoms located in the knees, regardless of their sensation; while the second rubric provides a completely independent and unrelated listing of remedies with joint symptoms which are tearing/drawing in nature regardless of their location (the Pocketbook combines “tearing” and “drawing” in one rubric). The

number of remedies listed in each of the two Pocketbook rubrics is quite large because each rubric deals with only part of the whole symptom description.

Less detail can be better

You might question why you would design a repertory to perform in the same way as the second EH search. What advantage is there to having one rubric to list remedies with “knee” symptoms and another rubric to list remedies with “tearing”/”drawing” joint symptoms? Neither rubric lists “tearing” and “drawing”, and “knees” together as a single symptom and it would seem that combining them into a single rubric would be more practical and at the same time more accurate.

But if you think back on the 4th of the Boenninghausen insights you begin to see the method in this madness. Having one rubric for the sensation and another for the location breaks the connection between “tearing”/”drawing” and “knees”. The connection is broken because Boenninghausen regards symptom sensations as a general characteristic. The Pocketbook’s independent rubric for “tearing”/”drawing” will show us the occurrence of this particular sensation regardless of its location or accompanying modalities. It shows us a list of all remedies having “tearing”/”drawing” joint pain symptoms occurring in *any location*. The Pocketbook’s second rubric deals only with the location. It will show us all remedies with “knee” symptoms regardless of the type of sensation or accompanying modality present. Between the two rubrics we get every remedy with symptoms of either type and with this we have more possible remedy matches to our case – consequently fewer remedies excluded at the point of repertorization.

Certainly no case rests on a single symptom. To truly see the difference between these two repertory rubric styles we’re going to need some additional symptoms to make up an illustrative case. To our chief complaint of “tearing”/”drawing” pains in the knee, let’s add symptoms such as eruptions at the margins the anus, sensitivity to noise, an aggravation from jarring and inflamed corns on the feet. We’ll repertorize all these

symptoms first with Synthesis and then with the Pocketbook so that we can compare the results obtained with the two repertories. The Synthesis analysis chart follows here:

The screenshot shows the 'Investigation window for remedies' in Synthesis software. The window title is 'Investigation window for remedies'. The interface includes a search bar with '125 %' and 'Millennium view (progressive)'. There are icons for 'Display', 'Strategy', and 'Restrict to'. The main area shows a list of rubrics under the heading '1. Synthesis':

- 1. EXTREMITIES - PAIN - Knees - tearing pain - drawing pain (6) 1
- 2. MIND - SENSITIVE - noise, to (221) 1
- 3. RECTUM - ERUPTIONS - Anus; about (38) 1
- 4. GENERALS - JAR, stepping - agg. (114) 1
- 5. EXTREMITIES - CORNS - inflamed (13) 1

Below the list is a grid with 30 columns representing remedies (sulph., nit.ac., sep., calc., caust., lyc., rhus-t., ant.c., hep., staph., thu.j., stann., sil., graph., nat.m., puls., at.g.n., borx., kali.c., nats., petr., phos., ars., carbns., cham., ign., merc., am.c., chel., borx.) and 5 rows representing the rubrics. The grid shows the degree of each remedy in each rubric. For example, Sulphur has a degree of 1 in all rubrics, while Nitric Acid has a degree of 2 or 3 in rubrics 2-5 but 0 in rubric 1.

At the bottom of the window, it says '246 remedies / 5 symptoms', 'Sum of symptoms, sort: degree', 'No restriction', and 'All remedies considered'.

There are 246 remedies on the Synthesis chart with only 1 of those remedies, Sulphur, appearing in all the rubrics used. The smallest rubric in this analysis is the first one for “tearing”/”drawing” pain in the knees. It contains only 6 remedies. (Or to put it another way, it eliminates 240 remedies.)

Look at the 2nd remedy listed on the chart, Nitric Acid. It has a grade level of two or three in every rubric except the first, where it does not appear at all. This is a remedy known for its sensitivity to slight causes, such as noise, and also its aggravation from jarring. It is also known for eruptions at the margins of the body’s openings. Nitric Acid covers the concomitant symptoms very well but it is excluded from the first rubric for the chief complaint of tearing/drawing knee pain. We might not consider Nitric Acid in this analysis because it is not included in our chief complaint.

The next chart shows the analysis of these same symptoms using the Therapeutic Pocketbook. The Pocketbook’s chart contains 7 rubrics and lists 125 remedies. Of these

125, there are 6 remedies appearing in all the rubrics we've used. The Pocketbook is suggesting that five additional remedies meet all the symptom requirements found in our simulated case of tearing/drawing knee pain.

The screenshot shows a software window titled "Investigation window for remedies" with a magnification of 125%. The window displays a list of symptoms under the heading "Therapeutic Pocketbook":

1. Sensations and complaints - External parts of body and internal organs in general - tearing (drawing) - Joints; in the (104) 1
2. Parts of the body and organs - Lower limbs - Joints - Knee joint (117) 1
3. Change of general state - Aggravation - noise; from (43) 1
4. Change of general state - Aggravation - stepping (hard); from (68) 1
5. Parts of the body and organs - Anus - Rectum (87) 1
6. Sensations and complaints - Skin - eruptions - general; in (124) 1
7. Sensations and complaints - Skin - corns - inflamed (12) 1

Below the list is a grid of remedies (columns) and their degrees for each symptom (rows). The remedies listed are: sep., lyc., calc., sil., puls., nit-ac., sulph., nux-v., rhus-t., caust., bry., chin., bell., kalif-c., mer-c., phos., con., nat-c., spig., anac., am., sabad., staph., alum., am-c., ang., cham., stann., borx., m.

	sep.	lyc.	calc.	sil.	puls.	nit-ac.	sulph.	nux-v.	rhus-t.	caust.	bry.	chin.	bell.	kalif-c.	mer-c.	phos.	con.	nat-c.	spig.	anac.	am.	sabad.	staph.	alum.	am-c.	ang.	cham.	stann.	borx.	m.
1.	4	4	3	2	2	1	4	3	4	4	3	3	2	4	4	3	1	2	2	2	2	1	2	2	2	1	2	2	-	1
2.	4	3	3	2	4	3	4	4	4	4	3	4	2	3	3	3	2	2	3	3	2	2	3	2	2	1	1	3	1	1
3.	3	3	3	2	1	1	-	4	-	1	2	2	3	1	1	-	3	3	3	2	3	2	-	1	1	3	3	1	2	1
4.	3	3	3	4	2	2	3	3	4	3	4	3	3	1	1	3	4	3	2	3	3	3	1	2	2	3	1	1	1	1
5.	4	4	4	2	2	3	4	4	2	3	1	3	3	3	4	1	2	2	2	2	1	3	1	3	1	1	1	2	2	2
6.	4	4	4	4	3	3	4	2	4	4	3	1	2	3	3	1	3	2	2	1	2	1	3	1	3	1	2	1	2	1
7.	3	3	2	4	1	1	2	-	2	-	-	-	-	-	1	-	-	-	-	-	-	-	2	-	-	-	-	-	1	-

At the bottom of the window, it shows "125 remedies / 7 symptoms", "Sum of symptoms, sort: degree", "No restriction", and "All remedies considered".

The smallest rubric in the Pocketbook's analysis is the one for the corns and it contains 12 remedies. That's only one remedy less than is found in the corresponding rubric used in the Synthesis analysis. So the way the two repertories represent the symptom of inflamed corns is not making much of a difference. The difference between the two analyses comes entirely from the manner in which each repertory represents the tearing/drawing knee pain. Earlier we looked at how the Pocketbook represents this symptom by using two rubrics; the first includes the symptom sensation and lists 104 remedies and the second rubric includes the symptom location and lists 117 remedies. While the Synthesis repertory represents this symptom using a single rubric that includes both the sensation of the pain and also its location and contains just 6 remedies. Let's look more closely at this Synthesis rubric in order to see how well it corresponds to the materia medica.

Synthesis listed Sepia in 3rd place even though it is not in the rubric used for “tearing” and “drawing” knee pain. While Sepia is the first remedy on the Pocketbook’s analysis chart. If I search in EH under the remedy Sepia for the word “tearing” (and a list of synonyms including “drawing”) and also for the word “knees” I can find 441 symptoms with the words “tearing/drawing”, 153 symptoms with the word “knees” and 40 symptoms containing both “tearing/drawing” and “knees” in the same sentence. The remedy Sepia appears to have an abundance of “tearing” pains, and “drawing” pains, and also a strong affinity for symptoms in the knees. A small sampling of “drawing” or “tearing” knee pains from the materia medica of Sepia appears below:

- Arthritic drawing in the knee and finger-joints,
- Tearing in the knee and elbow-joints(after sixteen days),
- Tearing in the whole thigh, particularly in the knees, after dinner and supper,
- Drawing pain in the knee-joints, evenings,
- Drawing and tearing shootings in knees, hams, and heels.¹³

Let’s look next at Nitric Acid. I can use EH to find 316 instances of “tearing/drawing” pains in various locations and 65 instances of knee symptoms. Most important though, I can find 18 instances of “tearing/drawing” pains associated with the knees some of which are listed below:

- Pressive-drawing pain about the knees, ankles, and other joints,
- Drawing and tearing in the thigh, extending from the knee upward, on sitting down, relieved by sitting,
- Tearing in the thigh, extending up from the knee, while walking,
- Violent drawing in the knees, ending with a jerking,
- Rheumatic pains and drawing from knee to groin, with soreness of testes.¹⁴

With the results we’re able to find using EH, we should wonder why Synthesis does not include either Sepia or Nitric Acid in its rubric **Extremities-pain-knees-tearing pain-drawing pain**. The reason for this is that neither Sepia nor Nitric Acid has pains which are

¹³ Allen’s Encyclopedia of Pure Materia Medica is the source for all symptoms save the last one which comes from Clarke’s Dictionary of Practical Materia Medica

¹⁴ Allen’s Encyclopedia of Pure Materia Medica is the source for all symptoms save the last one which comes the proving of Nitric Acid found in Hughes’ A Cyclopaedia of Drug Pathogenesis

“tearing” and also “drawing” *and* which are also located in the knees. Still, the EH searches we’ve done using the words “tearing”, “drawing” and “knees” turned up numerous instances of symptoms with these features for both remedies. Without doubt a “tearing” and “drawing” knee pain is well within the realm of the possible for both remedies (Sepia had 40 knee symptoms with tearing or drawing pains. Nitric Acid had 18 similar symptoms). The Pocketbook’s analysis on page 40 which looks at the location “knees” and the sensation “tearing/drawing” separately, and which includes both Sepia and Nitric Acid in its top six remedies, is definitely indicating this possibility.

Which repertory analysis is more accurate then, Synthesis or the Pocketbook? I’m going to beg this question for just a little longer. I’d like to return to the Synthesis analysis on page 39 once again. If I make a minor rubric change – a Boenninghausen-like substitution – by removing **Extremities-pain-knees-tearing pain-drawing pain** and replace it with the two more general rubrics of **Generals-pain-drawing pain** and **Extremities-pain-knees-tearing pain** then the Synthesis analysis chart on page 39 changes from having a single remedy appearing in all of its rubrics to now having seven remedies which appear in all of its rubrics. Those remedies are Nitric Acid first, followed in order by Rhust-t, Lycopodium, Sepia, Sulphur, Calc carb and Hepar. Note that four of the seven remedies in this modified Synthesis analysis, which appears on the next page, were in the top six remedies in the Therapeutic Pocketbook’s analysis on page 40.

In this modified version of the Synthesis analysis we’re using two generalized rubrics to replace one complex rubric. In doing this we haven’t changed anything about the actual symptom itself, only how we’re representing it with the repertory. Comparing the two versions of the Synthesis analysis we can see now how the rubrics we choose to represent a symptom can have a profound effect on the analysis results. This modified Synthesis chart is not necessarily more accurate than the original version on page 39, but it is definitely more *inclusive*. We also see that this modified chart looks a lot like the analysis chart from the Therapeutic Pocketbook on page 40.

Investigation window for remedies

125% Millennium view (progressive)

Display Strategy Restrict to

3 Synthesis modified

1. EXTREMITIES - CORNS - inflamed (13) 1
2. GENERALS - JAR, stepping - agg. (114) 1
3. RECTUM - ERUPTIONS - Anus; about (38) 1
4. MIND - SENSITIVE - noise, to (221) 1
5. GENERALS - PAIN - drawing pain (130) 1
6. EXTREMITIES - PAIN - Knees - tearing pain (126) 1

	nit-ac.	rnust-t.	lyc.	sep.	sulph.	calc.	hep.	sil.	puls.	caust.	kalif.c.	phos.	chel.	merc.	petr.	staph.	ars.	starn.	thuj.	am-c.	graph.	bell.	acon.	arn.	bry.	chin.	lach.	led.	n'
1	2	3	4	5	6	7	8	9	10	11	12	13	14	15	16	17	18	19	20	21	22	23	24	25	26	27	28	29	
6	6	6	6	6	6	6	5	5	5	5	5	5	5	5	5	5	5	5	5	4	4	4	4	4	4	4	4	4	
15	13	11	11	11	10	8	13	11	9	9	8	7	7	7	7	6	6	6	5	10	9	8	8	8	8	8	8	8	
1.	2	1	2	2	3	1	1	3	2	-	-	1	-	-	2	-	-	-	-	-	-	-	-	-	-	-	-	-	
2.	3	3	2	2	2	2	2	3	2	1	2	1	1	1	1	1	1	1	2	1	2	3	2	3	2	3	2	2	
3.	3	2	1	1	2	2	2	-	-	2	1	-	1	1	3	2	1	1	1	1	2	-	-	-	-	-	-	2	
4.	3	1	2	3	1	2	1	3	2	2	3	2	1	2	1	1	2	1	1	1	3	3	3	2	2	3	2	-	
5.	3	3	1	1	1	1	1	2	2	1	1	1	3	1	1	1	1	1	1	3	1	1	1	1	2	1	1	1	
6.	1	3	3	2	2	2	1	2	3	2	3	2	1	2	1	-	1	2	1	1	-	2	2	2	1	2	2	3	

317 remedies / 6 symptoms Sum of symptoms, sort: degree No restriction All remedies considered

So now to get back to the issue of which repertory has the greater accuracy. Accuracy in case analysis is achieved through the questions we ask during the interview and by the symptoms we select for our symptom hierarchy. These crucial steps take place before we open the repertory. I'd like to say at this point that the accuracy of these two repertories isn't really the issue at all. The real issue when it comes to the repertory stage of case analysis is that of missing our remedy by inadvertently filtering it out through our choice of rubrics – this is the error of *exclusion* referred to earlier by Will Taylor.

We've seen that the Therapeutic Pocketbook is inclusive by design rather than exclusive. This arises from two sources. The Pocketbook's rubrics are for the most part larger because they are more general in nature. They bring more remedies into the analysis at the outset; one reason for the Pocketbook's analyses containing more remedies. The other source of the Pocketbook's inclusiveness is the manner in which symptoms are broken down into their component features and dispersed throughout the repertory's chapters. Each instance of a complex proving symptom with its description of location, sensation and modality will generate rubrics that appear in at least three chapters. Such a symptom can be retrieved again either through a rubric describing its modality, or a rubric

describing its sensation, or one describing its location. This increases its representation in the repertory threefold and consequently it has three times as many chances of being included on a repertory chart. The benefit to the student of this over representation in the repertory is immediate. Using the Pocketbook we are much less likely to eliminate the correct remedy by inadvertently filtering it out through our inexperienced rubric selection.

There is, however, one minor drawback to the way in which the Pocketbook's rubrics are displayed in the analysis. Just looking at the analysis chart on page 40 there's no way for us to tell which remedies have "tearing" and "drawing" and "knee" symptom features occurring together in the same symptom and which remedies don't. The Pocketbook does not combine these features into a single rubric allowing us to see this immediately. For example, Chamomilla appears in all of the rubrics on the chart and is listed in 27th place in the analysis. When we go to the Materia Medica we read there that Chamomilla has "tearing" and "drawing" pains, and "knee" pain as well, however it does not have "tearing" or "drawing" pains which occur in the knees. The Pocketbook's tendency to be more *inclusive* brings Chamomilla into the analysis despite this. So in order to know if a remedy appearing in our analysis is there because it has the particular sensation(s) we're looking for, occurring in the particular location we're looking for it to be in; we're going to have to read its materia medica looking for symptoms with these features occurring together.

Rubrics of the Mind and Sensorium

The Pocketbook's chapter **Mind and Sensorium** contains only 36 rubrics. As we have come to expect now, these rubrics are sparse in their description referring to general qualities such as "excitement", "mildness" or "mistrust". The schema used elsewhere in the Pocketbook of breaking symptoms down into their constituent components could not be applied to symptoms of the Mind and intellect. Limiting the number of rubrics in this first part of the repertory was a choice made by Boenninghausen so that we would go directly to the materia medica for the mental/emotional symptoms.

In regard to the first section, it must be especially observed that our Materia Medica Pura contains nowhere more secondary symptoms than under the Mind and Disposition, and, on the other hand, most beginners in homeopathy are liable to overlook this part of the picture of the disease or to make mistakes. Therefore, I have considered it wise to give here only what is essential and prominent, under as few rubrics as possible, in order to facilitate reference. (Roberts, p. 25)

Boenninghausen was quite Hahnemannian in his judgment of the importance the patient's state of disposition has in arriving at the homeopathic diagnosis. He knew that often the mental and emotional symptoms hold sway over the case and are most characterizing. He suggested that after we repertorize the physical symptoms to arrive at a list of leading remedies which match those features, we should then turn to the materia medica to study the mental symptoms of those remedies in more detail. There we can read the mental/emotional symptoms in the richness of their original context to more accurately discern the remedy most suitable to the case. In this way the mental/emotional symptoms come into play in the final determination of the remedy choice. (Taylor, "Understanding the Boenninghausen Method")

Repertory analysis of partial symptom descriptions

In a perfect world we would always obtain symptoms in their full detail. In actuality this is far from a regular occurrence. Perhaps we are unable to obtain a full symptom description because we lack the skills to question our patient in some area, or it may be

that the patient cannot recall a particular detail of his/her symptoms as they have long since become habituated to them.

As students we are taught that symptom detail is necessary in order to more exactly determine the simillimum. However if we attempt to repertorize a less than completely described symptom, by selecting a complexly worded rubric containing a lot of detail, we can run up against a problem. The symptoms referred to by such rubrics are often more precise than the partially described symptom given by our patient, who may only be able to vaguely describe a sensation, or who cannot tell us the exact location, or who describes a symptom without any modalities whatsoever. The fit between the partially described patient symptom and the precise symptom description of the detailed rubric will not be a good one in this situation. Whenever we opt to use a detailed rubric we must carefully confirm the closeness of the match between its details and those of the patient's symptom – as the symptom detail inherent in their wording will be found in only a limited number of remedies. Including a specifically-worded rubric in our repertorization without this confirmation will eliminate many potentially good remedy matches and most likely lead our analysis astray.

The Therapeutic Pocketbook can make life easier for us in such instances. You may recall that whole symptoms are intentionally broken down into their components when entered into the Pocketbook and that these component rubrics are recorded in separate chapters. This makes it possible to retrieve a rubric for just a single symptom component – that is only the sensation or the location or the modality – independent of the other components that originally accompanied it in the proving. The rubric can be matched to the partial, or fragmented, symptom description provided by our patient. Should our patient describe a symptom's location and sensation without being able to recall a modality we can accurately repertorize this incomplete symptom using two rubrics. The first rubric references all remedies known to have symptoms in the same location as our patient, while the second rubric references all remedies known to have symptoms with the same sensation as our patient. Neither rubric attempts to link the location and the sensation together and of course neither rubric says anything whatsoever about the missing modality. Both rubrics will contain a larger number of remedies because each

rubric only looks at one aspect of the symptom rather than at both together. This serves to keep the field of potential remedies as large as possible.

(An analogous example would be for us to have one list of the names of all animals found living in the tropics and then another list of the names animals with white fur. Each of these two lists would contain a great many more animals than you would find in a list restricted to only those animals which both live in the tropics and which also have white fur.).

I'd like to introduce an example to show how the Therapeutic Pocketbook easily accommodates imperfectly described symptoms while at the same time demonstrating an instance in Synthesis of an "error of exclusion" referred to earlier by Will Taylor. Using Synthesis and then the Pocketbook we will find rubrics for the symptom "**vertigo accompanied by mental confusion worse lying in bed**". This is a portion (i.e., an incomplete or partial description) of the vertigo symptoms from the Conium proving on page 24 and which I've listed here again just to refresh our memories. You can see in the list below that "lying" and "bed" are features in the vertigo of Conium and are accompanied by some mental confusion:

- Dizziness and whirling in the head for two days.
- Very dizzy while walking.
- forgetfulness and weakness of the head; vertigo, when looking around, as if the patient would fall to one side;
- Vertigo, whirling around when he rises from his seat.
- Vertigo, after stooping, when raising up again, as if the head would burst.
- Vertigo, worse lying down, as if the bed were whirling around in a circle.
- Vertigo, early on rising from the bed.
- Headache (externally), as if contracted, on the upper part of the frontal bone, which goes off by stooping and applying his own hand to the part, with chilliness, vertigo, and peevish want of recollection
- Vertigo on going down stairs; she had to hold on to something, and for a moment she did not know where she was.
- Vertigo which fatigues the head.
- Vertigo, so that everything seems to whirl around.

First we'll repertorize the symptom in Synthesis using three specifically worded rubrics which appear to be quite appropriate for this symptom. Then we'll do a second Synthesis analysis employing more general rubrics to see how using less specific rubrics changes

the analysis. We'll discuss the reasons for the differences we see in these two Synthesis analyses before going on to repertorize this same symptom using the Therapeutic Pocketbook.

In the first chart below, the Mind rubric seems a good match to the description in our example. The two Vertigo rubrics have been combined into a single rubric group in order to include all the remedies found in either one of them. They represent the associated modality of worse lying in bed. The wording of these three rubrics seems to fit this symptom very well.

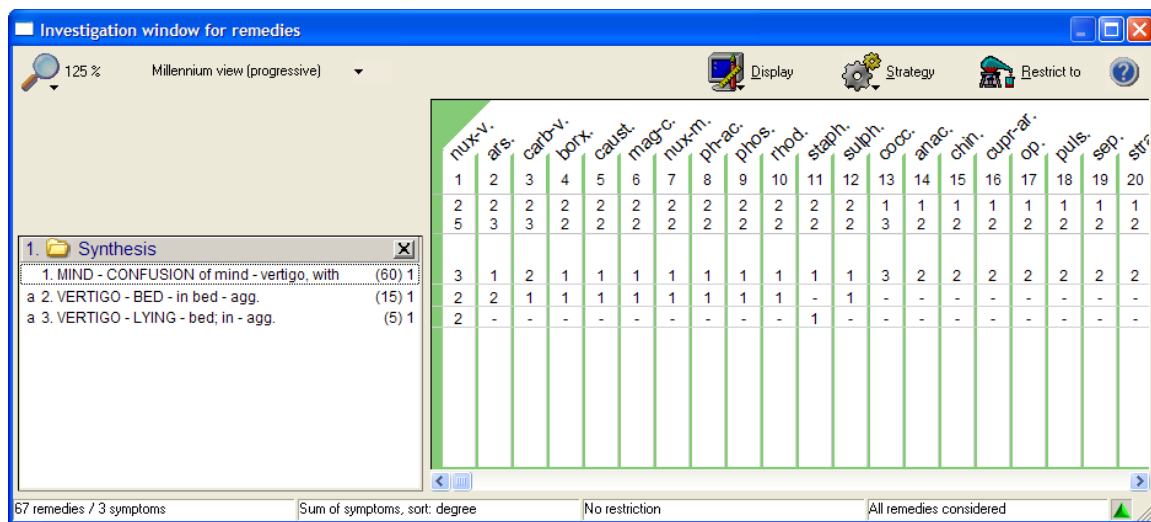

However, Conium does not appear in any of these rubrics and yet we know that the symptom itself comes from the Conium proving. Even the Mind rubric for confusion with vertigo does not list Conium among its sixty remedies. This analysis contains a total of 67 remedies.

Now let's make some modifications to our rubrics. Conium does not appear in the rubric **Mind-confusion of mind-vertigo, with**. We can substitute the rubric **Mind-Confusion of mind** to get around this problem. Conium also doesn't appear in **Vertigo-Bed-in bed-agg** or in **Vertigo-lying-bed; in-agg** but if we substitute the less specific **Vertigo-lying-agg** Conium will again appear on the chart. I've combined the initial Synthesis analysis on the same chart with the modified Synthesis analysis so that we can compare the two approaches. The rubrics in the initial analysis have a weighting factor of zero so that they do not

influence the outcome of the modified analysis. You'll notice that the first Synthesis analysis listed 67 remedies while this second more general analysis lists a whopping 573 remedies.

The screenshot shows the 'Investigation window for remedies' with the following analysis steps:

- 1. Modified analysis (569) 1
- 2. VERTIGO - LYING - agg. (74) 1
- 2. Initial analysis
- 3. MIND - CONFUSION of mind - vertigo, with (60) 0
- 4. VERTIGO - BED - in bed - agg. (15) 0
- 5. VERTIGO - LYING - bed; in - agg. (5) 0

The grid below shows the number of remedies for 28 symptoms across five analysis steps. The symptoms are: carb-v., con., lach., mus-t., calc., cro-t-c., merc., nux-v., petr., docto., puls., sep., sil., stry., thuji., alum-n., apis, ars., aur., bar-c., calc-sil., Carb-bran., Calust., Cham., ferr., graph., heil., lac-c., m.

	carb-v.	con.	lach.	mus-t.	calc.	cro-t-c.	merc.	nux-v.	petr.	docto.	puls.	sep.	sil.	stry.	thuji.	alum-n.	apis	ars.	aur.	bar-c.	calc-sil.	Carb-bran.	Calust.	Cham.	ferr.	graph.	heil.	lac-c.	m.
1.	3	2	3	3	3	2	3	3	3	3	2	3	3	3	2	2	1	2	2	2	2	1	1	2	2	2	2	2	2
2.	2	3	2	2	1	2	1	1	1	2	1	1	1	2	1	2	1	1	1	1	1	2	2	1	1	1	1	1	1
3.	-	-	-	-	-	1	3	-	-	2	2	1	-	-	-	-	1	-	-	-	1	1	1	-	-	1	-	-	
4.	1	-	-	-	-	-	-	2	1	-	-	-	-	1	-	-	-	2	-	-	-	1	-	-	-	-	-	-	
5.	-	-	-	1	-	-	-	2	-	-	-	-	-	-	-	-	-	-	-	-	-	-	-	-	-	-	-	-	

At the bottom of the window, it displays: 573 remedies / 5 symptoms, Sum of symptoms, sort: degree, No restriction, All remedies considered.

Clearly, the three rubrics included in the initial analysis are responsible for eliminating most of the remedies. This is due to their detailed wording in describing the vertigo. Somehow the additional information about the vertigo being worse in bed and that it is accompanied by mental confusion drastically reduces the number of remedies in the analysis, and also manages to exclude a remedy (Conium) that we know to have this symptom.

In the modified version of the Synthesis analysis we adjusted our rubrics to use ones with less specific detail because we knew ahead of time that Conium should appear in the chart. Using less specific rubrics is a strategy that we might not always think of and, as you can see, it can leave us with a huge field of remedies to work with. Besides, you say, don't we need to repertorize the sensation "mental confusion" and the modality "worse in bed" if that detail is included in the vertigo symptom description? That is an interesting

question and one we'll be discussing shortly. But for now let's continue looking at the rubrics we've selected for the two versions of the Synthesis analysis. Perhaps the problem is that we're not using the right rubric(s) and we need to find a rubric that matches the Conium proving symptom more accurately than the ones we've used so far. This could all be a matter of not knowing that a more appropriate rubric exists.

Indeed, there is a rubric in Synthesis that specifically captures the description of vertigo from the proving for the remedy Conium. That rubric is **Vertigo-turned about; as if bed** and it contains six remedies with Conium being a (3) in this rubric. Checking the author reference for Conium we see that it is Hahnemann and that the symptom comes from Chronic Diseases. This, then, is the exact rubric for the proving symptom and it does contain a reference to lying in bed.

But wait. In our example the patient has not given us a description of vertigo that includes it being “as if the bed turned about”. All we have in our description is “vertigo accompanied by mental confusion worse lying in bed”. Our patient is describing only part of the full symptom as it exists in the proving for Conium; and which, in Synthesis, is represented by the rubric **Vertigo-turned about; as if the bed**. Without our patient supplying the missing detail about the sensation of the bed moving we really can't use this rubric – and herein lays the problem.

The problem, in a nutshell, is that the precise detail in some rubrics is either excluding them as potentially good rubrics – when we don't have sufficient detail from our patient to use them (the situation with the rubric **Vertigo-turned about; as if the bed**) – or when we do include complexly worded rubrics their precise detail results in excluding potentially good remedies (the situation with the three rubrics used in our first Synthesis vertigo analysis).

If we're honest with ourselves now, we have to recognize that in selecting specifically worded rubrics we are choosing between them based solely on what we read in – and especially read into – their wording. We really have no other option at this early stage of our training. We should exercise caution when including rubrics with specific and detailed wording in our analysis. We've seen that the repertory is prone to make a type of

error, the “error of exclusion”, and it arises when we take the complex wording of some rubrics at face value as if they were faithful translations of proving symptoms. In this Conium vertigo example had we used the three rubrics from the first Synthesis analysis, based solely on their specific wording, we would have eliminated the correct remedy before we even opened up the materia medica.

Exactitude in case analysis is desirable for our initial prescription, perhaps even more importantly for our follow ups; but to strive for it at the point of repertorization through gravitating to smaller precisely worded rubrics is perhaps not the most constructive means of attaining the accuracy needed in order to arrive at the simillimum. I’d be lying if I said it hasn’t taken me quite some time to come around to see the truth of this. The eye opening moment came when I was listening to a teleconference on the Boenninghausen method posted on the [Whole Health Now](#) web site. Early in this recorded interview Will Taylor talks about how Boenninghausen generalized modalities and sensations in order to make up for the deficiencies in the provings and to “kind of cover over some of the gaps” in our knowledge of remedies.

“[Boenninghausen] never proposed that we impose these generalizations on our materia medica...But in the repertory this is a different story. He said the goal of the repertory is to go fishing with. ...we want to drag it through the water and we don’t want to miss the fish that we need to end up with. And so we might need to cast it a little bit broader than what we record in the materia medica for remedies...there might be another symptom...that just has not been observed in a proving; or yet confirmed in a clinical setting. And we would lose it in our analysis if we didn’t cast our net this broadly...this generalization of modalities and generalization of sensations is something intended for the repertory and not to rewrite the materia medica in this manner”. (Taylor, "Understanding the Boenninghausen Method")

I’d like to repertorize the same partially described Conium symptom of **vertigo accompanied by mental confusion worse lying in bed** now using Boenninghausen’s Therapeutic Pocketbook. You can see from the analysis chart on the next page that the Pocketbook’s rubrics contain far less descriptive detail than the rubrics used in the initial analysis with Synthesis.

Investigation window for remedies

125% Millennium view (progressive) Display Strategy Restrict to

1. Therapeutic Pocketbook

1. Mind and Sensorium - Confusion [cloudiness, etc.] - vertigo (117) 1
2. Mind and Sensorium - Confusion [cloudiness, etc.] - confusion of mind, fogginess (68) 1
3. Change of general state - Aggravation - lying; while - bed; in (122) 1

	puls.	bell.	calc.	laur.	phos.	rhust.	verat.	arg-met.	bry.	kalif.c.	lyc.	nux-v.	op.	phrac.	sep.	sil.	cann-s.	con.	mez.	petr.	rheum	rhod.	stram.	sulph.	valer.	acor.
1	2	3	4	5	6	7	8	9	10	11	12	13	14	15	16	17	18	19	20	21	22	23	24	25	26	
3	3	3	3	3	3	3	3	3	3	3	3	3	3	3	3	3	3	3	3	3	3	3	3	3	3	
10	9	9	9	9	9	9	8	8	8	8	8	8	8	8	8	7	7	7	7	7	7	7	7	7	6	
1.	3	4	4	3	4	4	3	2	3	2	2	4	2	3	3	3	3	2	3	2	2	3	3	3	3	
2.	3	4	3	4	2	3	3	3	4	3	2	3	4	3	2	3	3	3	2	3	2	3	1	2	1	
3.	4	1	2	2	3	2	3	3	1	3	4	1	2	2	3	2	1	1	2	2	2	3	1	3	2	

125 remedies / 3 symptoms Sum of symptoms, sort: degree No restriction All remedies considered

Being more general – less specific and thus less exclusive – they bring more remedies into the analysis (with 125 remedies) than the number listed in the first Synthesis chart (with 67 remedies). The Pocketbook is definitely the “broader fishing net” here. More importantly the Pocketbook’s rubrics bring in Conium, listed in 18th position, without requiring any rubric substitutions.

As we discussed earlier, there will be remedies suggested in the Pocketbook’s analysis that are going to be “false hits” – remedies containing some, but not all, of the symptom features we are looking for – and we will have to rule these remedies out through our study of their materia medica¹⁵. Admittedly, the Pocketbook’s analysis gives us a little extra work when it comes to the differential diagnosis because it provides a broader range of remedies for us to study. Still, it is far easier to eliminate an extra remedy or two suggested by the repertory than it is to find one that has been *excluded* by it. We’ll move on to discussing remedy differential diagnosis and the interpretation of the Pocketbook’s analysis in the next section.

¹⁵ Sixty-seven remedies appear in all three rubrics in the Pocketbook’s analysis chart above. We would definitely need to include concomitant symptoms in order to reduce the number of likely remedies to something manageable that we could then study in the materia medica.

Part IV: Interpreting the Pocketbook's analysis

The Therapeutic Pocketbook chart on the previous page contains 125 remedies in the analysis, 67 of these appear in all three rubrics simultaneously. This number seems high, especially when the Synthesis analysis on page 48 listed only 12 remedies that appeared in more than one rubric. Are we really to conclude that there were this many remedies in the materia medica of Boenninghausen's time known to have vertigo symptoms matching the description **vertigo accompanied by mental confusion, worse lying in bed**? We need to take some time to look more closely at this Pocketbook chart because the rubric design of the Pocketbook makes it most unlike Synthesis when it comes to interpreting the analysis.

The remedy Conium, which we know to have this particular vertigo symptom, is the 18th remedy listed in Pocketbook's analysis. In theory then, there are 17 remedies before it which might just as easily also have this symptom. We're going to have to differentiate between these remedies on the basis of this symptom alone and in order to do that we need to examine their materia medica for this symptom. Pulsatilla is the first remedy listed on the chart and we might assume from this that it has the vertigo features we're looking for and with more certainty than the 18th place Conium. Searching in Hahnemann's Materia Medica Pura (MMP) and Chronic Diseases (CD) under "vertigo" we can find several entries for the remedy Pulsatilla. I'll list them here:

- Violent vertigo, like intoxication.
- Vertigo, like that which occurs on turning round for a long time in a circle, combined with nausea.
- Vertigo (immediately), still worse the next day.
- Vertigo as from intoxication.
- Vertigo as if the blood mounted to the head, raking and grasping in it.
- Attacks of vertigo, intoxication, heat.
- Vertigo, especially when sitting.
- Vertigo in the morning on rising from bed; on account of it he must lie down again.
- Vertigo when taking a walk in the open air, which goes off on sitting down.
- Vertigo, he imagines he cannot stand (in the 1st hours).
- A kind of vertigo-when he turns the eyes upwards-as if he would fall, or as if he were dancing.
- Vertigo when stooping, as if he would fall down, as from intoxication; followed by inclination to vomit (aft. 6 h.).

- Vertigo when stooping down, so that she could hardly raise herself up again.
- Vertigo as from a weight in the head, when walking and stooping, with some whirling which was also felt when lying.
- Staggering when walking as if he had vertigo, and yet he is not giddy, in the evening (aft. 3 d.).
- Dullness in the head and vertigo, caused by moving.
- Vertiginous obscuration of the sight after sitting, on standing upright and commencing to walk (aft. 24 h.).
- Tightness of the chest and vertigo together with weakness of the head, when lying horizontally on the back, which, however, goes off on sitting upright.

Pulsatilla certainly has numerous symptoms of vertigo. There is vertigo as from intoxication, vertigo with a sensation of heat, vertigo worse walking in the open air and better sitting, vertigo associated with lying on the back, but none specifically worse lying in bed and none accompanied by mental confusion.

Let's look next at Belladonna, the second remedy appearing in the analysis, and its vertigo:

- Vertigo; objects seem to sway hither and thither.
- Whirling in the head, vertigo with nausea, as after rapid turning round in a circle, or as after the morning sleep following a nocturnal debauch.
- Vertigo as if all whirled round in a circle
- Attacks of vertigo, when at rest and when moving.
- A giddy feeling in the whole head, like vertigo, when sitting
- Vertigo and trembling of the hands, so that she could not do anything with them.
- When walking he staggers, holds on to the walls, complains of anxiety and vertigo, and often talks nonsense like a drunken person.
- Attacks of vertigo with obtuseness of senses for some minutes
- A weight in the upper part of the forehead, which causes vertigo and as it were intoxication
- Rushing noise in the ears, vertigo, and dull bellyache.
- Eructation and vertigo
- Vomiting, vertigo, and flying heat
- Paralysis of the lower extremities, she must lie down, with nausea, trembling, anxiety and vertigo.
- Fever : at night febrile chill, which was soon succeeded by heat of the body, and frequent micturation and weariness of the limbs; the following night a double febrile attack of the same kind, with vertigo and thirst

Here again we can see that Belladonna has lots of vertigo, especially with reeling like a drunken person and staggering, but it does not have vertigo that is worse on lying in bed nor vertigo accompanied by mental confusion.

Looking next at the vertigo of Calcarea carbonica (3rd in the analysis) we see that it has vertigo with weakness, lack of firmness when walking and standing, but again no indication of vertigo worse when lying in bed and none associated with mental confusion:

- Stupefaction of the head, like vertigo, all the afternoon
- Feeling of vertigo, as if the was lifted high up and thrust forward.
- Vertigo, as if about to fall down, with exhaustion.
- Vertigo, as if the body did not stand firm
- Vertigo from vexation.
- Vertigo on quickly turning the head, and also when at rest.
- Quickly passing vertigo, mostly when sitting, less when standing and still less when walking.
- Violent vertigo in stooping, then nausea and headache.
- Vertigo after walking, while standing and looking around, as if everything turned with her.
- Vertigo on walking out, as if about to stagger, especially in quickly turning the head.
- Vertigo and painful whirling in the head as if in a circle, in the morning on rising; especially very dizzy when walking and standing, with chill and pin-pricking in the left side of the head.
- Headache, also at times with vertigo, every morning on awaking.
- Pressive outward in the forehead, very severe and like vertigo; relieved by pressure with the cold hand, and disappearing when walking in the open air

We've now looked closely at the top three remedies listed on the Pocketbook's analysis chart on page 52 and found that despite their appearing prominently in the analysis, none of them has the symptom we're looking for. At this point we might conclude that either we've chosen the wrong rubrics or, worse still, that the Pocketbook itself is at fault.

Actually there's nothing wrong with our rubrics and the analysis is fine, it's how we're interpreting the analysis that's the problem.

Our intention at the outset of this example was to use a combination of Pocketbook rubrics to represent a complex symptom of vertigo. To do this we chose one rubric for the vertigo, another for the mental confusion and a third for the modality of worse lying in bed. Quite understandably we selected these rubrics with the assumption that we could

re-combine them in order to restore the original symptom from the proving again. For our particular vertigo symptom these three symptom features are connected, associated one with the other as they occur at the same time in our patient. But in the Pocketbook they are not associated at all. Remember, these are *generalized* rubrics of symptom components that have been derived from many proving records. The Pocketbook's three rubrics present us with three unrelated lists: all remedies with the sensation of vertigo (in the 1st rubric), all remedies with the sensation of mental confusion (in the 2nd rubric), and all remedies with the modality of worse lying in bed (in the 3rd rubric).

If we can change how we view these rubrics, seeing them as three *independent* lists of symptom components and NOT as a three-rubric match for **vertigo worse lying in bed with mental confusion** we will be able to look at the Pocketbook's analysis in a different light. Now we can see that Pulsatilla, Belladonna and Calcarea appear on our repertory chart because each of these remedies displays symptoms of vertigo somewhere in their provings, each also has some symptoms that are worse lying in bed and each has some symptoms of mental confusion. And really, this is all we can take at face value from the analysis. To know whether or not a particular remedy appearing on the chart does in fact have vertigo that is specifically worse when lying in bed and which is accompanied by mental confusion – to confirm or reject this – we have to go beyond the repertory to read the materia medica of that remedy in detail.

We began Part III of this introduction to the Pocketbook with a quote from Will Taylor in which he said that we should not rely on the repertory to provide a “definitive description of individual remedies”. It is almost unavoidable that new students use the repertory as if it did provide such description, as if we could match its abbreviated symptoms on a one-to-one basis to symptoms we have acquired from the patient. Though we may begin like this, our use of the repertory changes as our knowledge of remedies grows and our experience in analyzing the case grows as well. After we've gained some experience in case analysis we find that we don't open the repertory until we have formed a hierarchy of the key symptoms from among the most consistent and distinctive features of the patient's illness (Aphorism 153). Then with the aid of the repertory we delimit the field of remedies most homeopathic to those symptoms. When we use the repertory this way it

reminds us of the themes present in the case that must also be present in our remedy. The analysis chart it generates will display the distilled genius of the case – that minimum number of symptoms of maximum value to the prescription. (Kellerstein)

In case analysis the primary strength of the Therapeutic Pocketbook lies in its taking the broadest possible approach to the first crucial aligning between the symptoms of our patient and those of remedies. The Pocketbook's inclusive approach ensures that we do not eliminate a remedy too soon at this early stage of our analysis. As we look over the analysis chart there will be a remedy or two which resonates with us and for which we may experience the feeling that "This remedy could very well be my patient". In getting us to this point the repertory has done all it can do for us. Those remedies we are still considering for the case must now be investigated in depth using the materia medica. Most likely we will need to examine several remedies, comparing one to the other on the basis their similarity to the symptoms exhibited by our patient. In the course of this study we will have the opportunity to deepen our knowledge of materia medica relevant to the symptoms of our case and to increase our knowledge of the similarities and differences between remedies that serves us so well at the bedside. At the start of our studies when we mechanically plugged patient symptoms into the repertory with the belief that it would find the 'right' remedy for us this quality of analysis was beyond our reach.

Part V: A case from Year III Clinic

The time has come to see the Pocketbook approach at work in an actual case. To demonstrate this I would like to re-visit a case from my third year clinic in order to compare my initial Synthesis analysis with an analysis using the Pocketbook. I will use the patient name assigned by the clinic supervisor so that if you wish to pursue this further you can view the video tape of the interview. The case comes from the third year clinic that ran from September 2006 to June 2007. The patient's name is Deanne.

Deanne – initial interview

Symptom Details

Fatigue –

- Easily after slight exertion
- With aches in muscles
- Mind awake but body tired
- Like she's "run a marathon"

Joint/back/wrist/hip pain –

- Hip
 - Like in the bone but it is not
 - "puncturing me"
 - Extends through the back
 - < sitting a long time
 - < lying on it
 - Superior iliac spine
 - Comes and goes/sharp and dull
- Back
 - Dull ache
 - Excruciating
 - < sitting for a long time
 - < any exertion
 - Across lower back
 - Frequent occurrence
- Wrists
 - Dull ache
 - < exertion
 - < typing

- < change in temperature
- Knees and ankles
 - < any exertion
 - Right knee extending down the front to the ankle
 - Like shin splints
 - Sharp shooting pain

Flatulence -

- Eructations and flatulence
- With distension of abdomen
- Accompanied by hunger
- Hunger returns soon after eating (20 minutes) < 9-10 pm

Migraine headaches -

- < change in weather
- < cold to hot
- < spring time worse than fall
- < sound, light and vomiting
- Headache accompanied by vomiting, < vomiting which increases the nausea and pain, > sleep and dark chocolate
- In the right eye extending to cheek bone underneath
- Can't think during the headache
- Stress headaches, < emotional things, when a paper is due, when worried.
Accompanied by panic and anxiety, thinking of the worst that could happen.

Flushes of heat -

- < afternoons; 4 to 6 pm
- Accompanied by flushed face (flushing only on the face). With red cheeks across the nose and cheekbones. With exhaustion and weakness and poor concentration. With nausea and vertigo, < rising, sudden light or sound and any motion. With a ghostly white complexion, blurred vision, pain in the eyes, > closing the eyes. With irritability.

Excessive Hunger -

- Will eat from 4 pm until bed time
- Will wake to eat
- Hungry again 20 minutes after eating
- Prefers salty things, then sweet things, then salty things, then sweets
- Loves tomatoes

Eruptions on hands and in mouth -

- Within mouth. Like a blister, pops and becomes an ulcer. Oval shaped with white center. Inside the mouth only, under the tongue, back of throat and cheeks.
- On hands. The palmer surface of fingers and hands. On the dorsal surface near the joints. Small red vesicles that are raised and stinging < touch. Occur once per week.

Synthesis analysis: hierarchy of symptoms (with weighting)

Deanne's list of symptoms appeared endless, with so many symptoms well described and occurring regularly that my case notes went on for nearly 10 pages. In the student clinic discussion following the interview the task before us was to pare down the details of the case to the essentials. I arranged the more intense and consistent symptoms in the following order:

1. Flushes of heat with weakness, vertigo and nausea (4)
2. Fatigue after slight exertion (4)
3. Joint/back/hip/wrist pains (3)
4. Migraines (3)
5. Excessive hunger (2)
6. Eruptions on hands and in mouth (3)
7. Aggravation from clothing around the neck (3)

My initial repertory analysis for this case contained no less than 36 rubrics. With this many rubrics all I was doing was listing her symptoms without analyzing their importance. I managed to trim this number down to 11 rubrics that in my judgement captured the four most prominent features of Deanne's case:

1. Flushes of heat in the afternoon with weakness, vertigo and nausea
2. Fatigue from slight exertion
3. Worse from a change of weather from cold to warm
4. Aversion to clothing around the neck

The analysis chart appears on the next page.

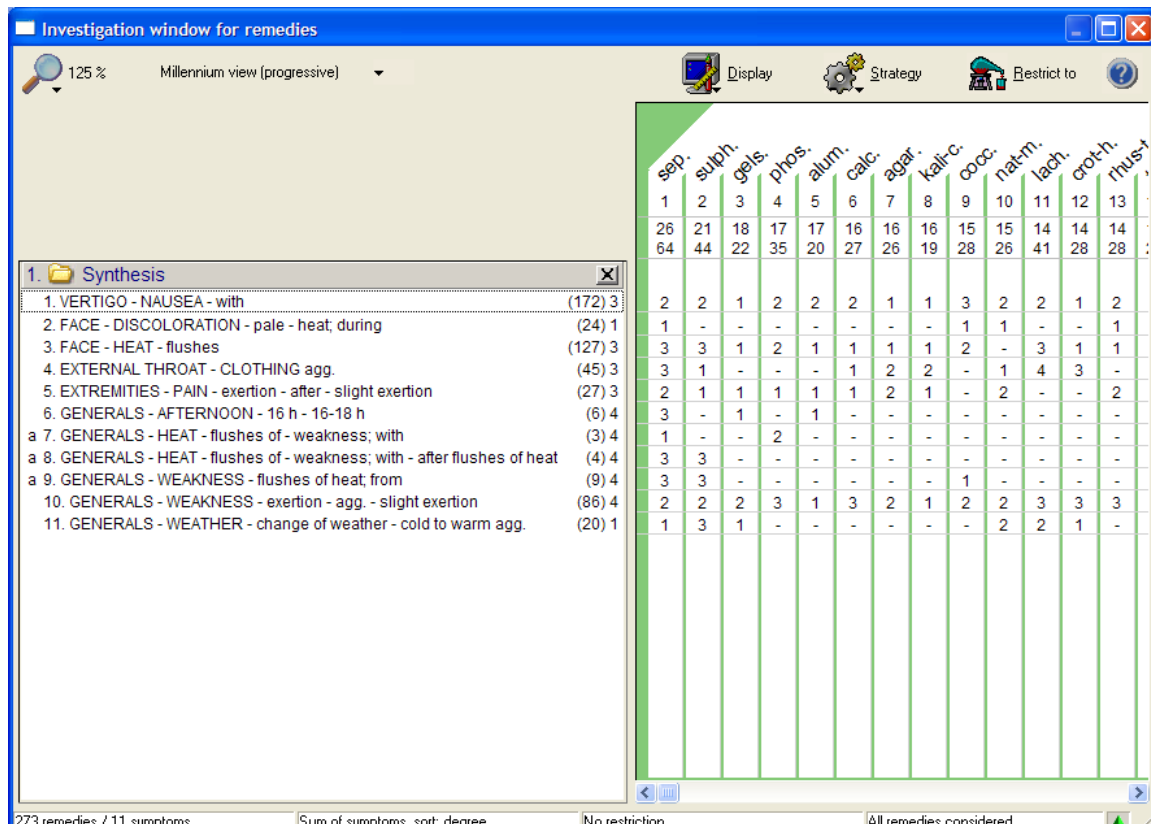

From the chart above you can see that one remedy stands clearly ahead of all the others. Sepia was in fact the remedy selected by our clinic supervisor, Dr. Kellerstein, for Deanne. Let me draw your attention to rubrics 7, 8, and 9 from the chart above. Despite combining these rubrics into a single group they still have the effect of drastically eliminating most of the remedies from the analysis. They have this effect on the analysis because they are complex rubrics each containing two symptom components – both a sensation and a modality. Their precise and exact wording seems to be a good fit for the description of heat in the afternoon, with paleness of the face, vertigo, blurred vision, nausea and vertigo given by Deanne. But as we have seen, earlier and again in this case example, this precision comes at the expense of excluding a large number of remedies from our consideration. The fourth rubric, **External Throat – clothing agg** was included because of an immediate and spontaneous response of “No!” when Deanne was asked if she could wear turtlenecks.

I remember congratulating myself on some pretty good rubrics when I found out that Deanne had received Sepia and had responded extraordinarily well to it. Looking back at this analysis chart today I see it differently. Frankly, I had managed to exclude so many other remedies as a result of the rubrics included in my Synthesis analysis that I really didn't have any other remedy choice at all. If Sepia had not worked for Deanne, I had nothing else to go on.

Next we'll begin an analysis of Deanne's case using the Therapeutic Pocketbook.

Therapeutic Pocketbook analysis: hierarchy of symptoms

The Boenninghausen method is embodied in the Therapeutic Pocketbook. You really can't use it without also using the method. Recall that the hierarchy of symptoms for Boenninghausen is not the same as for Kent. For one thing, you'll notice that there isn't a section for mental symptoms. This is not because such symptoms are excluded from a Boenninghausen analysis. Rather they are addressed under the categories of chief complaint, if presented as such, or as concomitant complaints. Boenninghausen's hierarchy of symptoms would begin something like this:

1. Causative modalities in the mental and physical spheres
2. Features of the chief complaint described in terms of:
 - a. Modalities
 - b. Sensations
 - c. Locations
3. Striking concomitants having a modalities, sensations or locations in common with the chief complaint.
4. Pathological physical generals: all other striking symptoms described in terms of:
 - a. Modalities
 - b. Sensations
 - c. Locations
5. Cravings and aversions
6. Accessory symptoms – those mental/emotional/physical features of the patient's "normal" state that can be used to differentiate between remedies should it become necessary.

An actual hierarchy of symptoms for any given case might begin this way but would be rearranged should a grand characteristic make itself apparent. Grand characteristics are those prominent, consistently present and well described modalities and sensations that appear in more than one symptom complex in the case, or which are not localized at all (such as having a patient tell you that they just have no thirst whatsoever or that they cannot tolerate the slightest draft of air). Grand characteristics leap to the front of the analysis and can even count more towards the prescription than the modalities of the chief complaint itself. Within the category of Grand characteristic symptoms we have the non-regional symptoms (those found in multiple locations or body systems), symptoms of the mind and disposition, the general symptoms and the modalities. (Dimitriadis, "How to use this Repertory", 2000)

Here is the analysis I made in Deanne's case for use with the Therapeutic Pocketbook:

- Non-regional modalities (consistent and present in more than one location)
 - Worse afternoon. Applies to exhaustion and hunger
 - Worse exertion. Applies to wrist and back pain
 - Worse change from cold to hot. Applies to migraines and to wrist pain
- Non-regional sensations (consistent and present in more than one location)
 - Dull ache. Applies to wrist and back pain
 - Weakness. Applies to the joint pain and occurs with the afternoon exhaustion, nausea, vertigo and flushes of heat
 - Flushes of heat. A general symptom. Part of an extremely well described symptom that occurs consistently combined with nausea, exhaustion and vertigo
- Concomitant symptoms (consistent)
 - Skin eruptions (vesicles) in the mouth and on the backs of the hand
 - Hunger from 4 pm until she goes to bed, accompanied by flatulence from 9 pm onward. Shares a time modality with the flushes of heat.
 - Pale face with flushes of heat, vertigo and nausea

The Pocketbook analysis chart appears on the next page. The rubrics are arranged according to Boenninghausen's classification scheme for a complete symptom – that is, according to sensation, location and modality.

Investigation window for remedies

125%

Display Strategy Restrict to

	sep.	bry.	nux-v.	calc.	puls.	chin.	caust.	spong.	am-c.	lyc.	sulph.	hep.	sil.	stann.	arn.	mus-t		
1	2	3	4	5	6	7	8	9	10	11	12	13	14	15	16			
38	38	37	37	37	37	37	37	37	36	36	36	35	35	35	34			
108	102	118	110	94	82	77	75	64	114	101	66	98	82	79	106			
2. Localisation																		
1. Parts of the body and organs - Upper limbs - Joints - Wrist	(103)	1	4	3	1	4	2	1	4	1	3	2	4	1	3	2	2	4
2. Parts of the body and organs - Face - sensations - Cheeks	(90)	1	2	1	3	3	3	2	4	3	1	2	1	2	1	3	3	4
3. Parts of the body and organs - Hunger and thirst - hunger	(99)	1	3	3	2	4	4	4	1	2	2	3	1	-	2	3	1	2
4. Parts of the body and organs - Nausea - nausea - general; in	(121)	4	3	3	4	3	4	3	2	1	2	3	4	2	4	3	2	4
5. Parts of the body and organs - Lower limbs - Leg; lower - Tibia	(86)	1	3	1	1	4	4	2	2	3	1	2	1	2	1	2	2	3
6. Parts of the body and organs - Face - color - pale	(94)	4	4	3	3	2	3	4	2	2	2	3	4	1	3	3	2	3
3. Sensation																		
7. Fever - Heat - flushes of heat, heat waves	(76)	4	3	2	3	2	1	2	1	3	1	4	3	3	2	3	3	2
8. Sensations and complaints - External parts of body and internal organs in general - dull pain	(77)	1	2	2	1	2	1	3	2	2	-	1	-	1	2	-	-	1
9. Sensations and complaints - External parts of body and internal organs in general - powerlessness...	(121)	4	4	3	4	4	3	4	3	2	2	4	3	1	3	4	2	4
4. Modalities																		
10. Change of general state - Aggravation - exertion; from - body; of	(70)	4	2	4	3	3	1	1	1	2	1	3	4	2	3	1	4	4
11. Change of general state - Aggravation - time; according to the - afternoon	(112)	4	1	1	3	2	4	1	1	2	3	4	1	1	3	1	1	1
12. Change of general state - Aggravation - heated, overheating; from becoming	(24)	1	2	4	2	-	-	-	-	1	-	-	2	2	-	-	-	-
5. Concomitant																		
13. Mind and Sensorium - Confusion [cloudiness, etc.] - vertigo	(117)	4	3	3	4	4	3	1	3	2	1	2	3	2	3	1	3	4
14. Sensations and complaints - Skin - eruptions - vesicular	(77)	1	3	3	-	1	1	3	3	2	2	-	3	3	2	-	-	4
15. Change of general state - Aggravation - pressure - clothes; from pressure of	(22)	3	3	3	4	4	1	1	3	2	2	4	1	3	-	3	1	-

125 remedies / 15 symptoms Sum of symptoms, sort: degree No restriction All remedies considered

Deanne: differential diagnosis

Sepia appears first in the Therapeutic Pocketbook analysis just as it did using Synthesis. The Pocketbook analysis chart though is much fuller with far more coherence and suggests more potential alternate remedies for the case. From the analysis chart we can see that the prominent features in Deanne's case are those also found in Sepia, Bryonia and Nux vomica. It would make our task easier if one of Deanne's modalities were unique to only one of the remedies we are considering, but we are not so fortunate.

We can begin our differential diagnosis between Sepia, Bryonia and Nux vomica by examining their consistent characteristics as they apply to Deanne. We see that Bryonia covers much of the case (having vertigo and nausea; weakness of the limbs; aggravation during the afternoon; aggravation from exertion and the sensation heat in the face) but does not have an aversion to clothing around the neck; furthermore Bryonia's pains are of a tearing and shooting nature rather than Deanne's dull aching pains.

Nux vomica seems a close fit as well (having sensations of heat, vertigo with obscuration of vision, weariness and pains following exertion and aggravations of its symptoms during the afternoons) but its pains are more drawing and constrictive, and it does not have the vesicular eruptions present with Deanne.

Calcarea carbonica is also a strong possibility for this case (with exhaustion, nausea and vertigo; sensations of heat in the face; quick fatigue from exertion; dull pains; aggravation of many symptoms during the afternoon) but does not have the aggravation from warmth which Deanne has.

Pulsatilla is worth considering (with attacks of vertigo, nausea and heat; weakness; an aggravation in the afternoon; vesicular eruptions) but its pains are drawing, tearing and ulcerative rather than dull and aching as Deanne has reported.

At this point in the differential diagnosis we haven't found a remedy matching all the features of the case and have only Sepia left to consider. Let's look now at how close a match we have in Sepia. Boenninghausen's Therapeutic Pocketbook is an index to Hahnemann's *Materia Medica Pura* and his *Chronic Diseases* so our reading will be limited to these works.

I can use EH to search the remedy Sepia to see how closely it matches Deanne's symptoms. First let's look at the chief complaint of weakness in the wrists, back and knees; worse slight exertion and heat. I can find several symptoms relating to pain in the wrist, more for symptoms in the knee and even more for symptoms in the back. Recall, though, that the location of a symptom is the least reliable feature on which to base our prescription. Let's look now at sensations and modalities as these are the features which largely determine the remedy diagnosis.

A second Sepia search for "weakness" yields several results:

- Great weakness of the knees
- Weakness of the muscles of the hand
- Nausea and weakness
- Fits of weariness
- At every movement of the body, he feels nausea, as if about to vomit and so weary, that in the open air, he had at once to lie down on the ground; all the limbs were devoid of tension.
- (There are a total of 53 search results indicating weakness is a widespread characteristic feeling for Sepia)

Next, for the modality of worse in the afternoon we can search for the word "afternoon":

- we find dizziness and vertigo every afternoon from 4 to 6 pm while sitting and walking (this is very close to Deanne's description)
- attack of heat, every day from one to six in the afternoon, for several days (this is close to Deanne's symptom)

For the modality of being worse for heat we can search Sepia for the words "heat" and "warm" which brings many more results (I had to use sources other than Hahnemann in order to find these symptoms):

- In hot weather: conjunctivitis always agg.
- Heat in the face, in the morning; in the evening, paleness of face.
- (a close match to Deanne with heat in the face and paleness)
- heat of the face and the hands, with paleness of the face,
- Follicular conjunctivitis or a mixed form of follicular and trachomatous conjunctivitis, which is observed only during the summer, or always agg in hot weather.
- Always aggr. in hot weather,

Searching Sepia for the modality of worse from exertion we can search for “exertion” and find these results:

- fits of weariness; readily tired when taking a walk; when exerting the body
- copious perspiration during slight bodily exercise;
- easily overstrained;
- After slight exercise, a flush of heat

For the sensation of dull pain we search for the two-word combination of “dull pain”:

- Dull pressive pain on a small spot of the occiput.
- Dull pain in the old roots of the teeth; cold things cause an acute pain to dart through them.
Dull pressive pain in the molars, with pain in the sub maxillary glands
- Heaviness in the stomach, with dull pain about the whole of the abdomen.
Dull, drawing, tearing, sprained pain in the shoulder-joint (after dinner).

For the accompanying vertigo we can search for the word “vertigo” and find:

- Dizzy vertigo, every afternoon from 4 to 6 o'clock, while sitting and walking.
- heat in the head with hardness of hearing and dim vision
- Vertigo every afternoon from 3 to 5 o'clock, everything turns in a circle around her, while walking, sitting and lying.
- (from these three results we have vertigo, altered vision and the time modality together)

Finally for the sensation of nausea we have the following symptoms:

- Bitter eructation with nausea.
- Attack of nausea, in the morning, while walking; things turned black before his eyes, there was heat from one P.M. till six P.M. with tearing in all the limbs, with long-continued nausea; in the evening, weakness even to swooning, with melancholy; everything affected his nerves, he was very easily frightened; at night an inordinate quantity of very fetid flatus was discharged
- At every movement of the body, he feels nausea, as if about to vomit and so weary, that in the open air, he had at once to lie down on the ground; all the limbs were devoid of tension.

The key symptom components in Deanne’s case – weakness, the aggravation from exertion, flushes of heat in the face, being worse in the afternoon, with nausea and vertigo – are repeatedly displayed throughout a great many symptoms from the Sepia proving. Using the process of completing symptoms by analogy we can transfer the recurring modalities and sensations exhibited in the Sepia proving to other Sepia symptoms in order to arrive at a composite symptom closely resembling the key features of Deanne’s case. We can do this so long as the sensations or modalities we are transferring from one part of the Sepia proving do not contradict any sensation or modality already present in

the proving symptom we are transferring them to. We may now compare our composite Sepia symptom to one of the pivotal symptoms in Deanne's case namely: flushes of heat in the face from 4 to 6 pm with nausea, exhaustion and poor concentration, vertigo, pale complexion and blurred vision. The Sepia proving symptoms listed below are excerpts from each of the searches outlined on the preceding pages:

- dizziness and vertigo every afternoon from 4 to 6 pm while sitting and walking
- attacks of heat, every day from one to six in the afternoon, for several days
- heat of the face and the hands, with paleness of the face,
- lack of firmness in the body; fits of weariness; readily tired when taking a walk; when exerting the body,
- heat in the head with hardness of hearing and dim vision
- Nausea and weakness.
- Stupefaction of the head, with tightness of the chest and weakness in the whole body

We can take this list of Sepia proving symptoms and by arranging the highlighted parts into a single composite proving symptom arrive at a description which is a strikingly close match to Deanne's well defined chief complaint:

Attacks of heat every day from 4 to 6 pm, with vertigo, heat in the face accompanied by paleness, weakness of the whole body with nausea, dimness of vision and stupefaction

Of the remedies we are considering from the Pocketbook's analysis, Sepia alone covers all the characteristic features of Deanne's symptoms (even including the concomitant symptom of her strong aversion to clothing around the neck). Sepia stands out in the differential diagnosis not because it has some rare feature which the other remedies lack. Rather "it is the combination of characteristics (themselves individually not distinguishing) which provides the unique identifier for the case" and it is this combination of symptoms which Sepia matches so well in Deanne. (Dimitriadis, Personal correspondence, 2007)

Differential diagnosis after repertorization marks the final step in choosing which remedy we will prescribe. This stage of case analysis is likely to involve a little more reading when using the Pocketbook. With the Pocketbook I've found that my materia medica searches have changed. I'm no longer seeking combinations of words in an attempt to find a symptom in the materia medica that matches a rubric. I know now that symptoms in the provings are often incomplete and that if I search using single word description of a sensation or modality I am far more likely to find a grouping of symptoms with the features that I'm looking for. Also I'm no longer searching for any single proving symptom to match all the details provided in the patient's description of their ailment. From Dimitriadis' work I know that I am able to transfer a remedy's recurring modalities and sensations from one reported symptom location in its proving to another (stopping short of contradicting a pre-existing sensation or modality) and that using this technique I can arrive at a composite symptom matching the prominent features of my case. Lastly, I know that I must always refer to the materia medica of each remedy under consideration to see whether the symptoms I have fashioned in the repertory appear recorded there. It's only after I've completed this thorough examination that I can determine the similitude of any remedy I'm considering prescribing.

Part VI: Clinical verification in the Therapeutic Pocketbook

Remedy grade levels

Boenninghausen knew that after proving symptoms had been recorded in the repertory the only way to assess their reliability was to follow their clinical performance. In the Therapeutic Pocketbook grade levels of 1 and 2 indicate characteristic proving symptoms for each remedy. A remedy would be entered with a grade level 2 when one of its symptoms was repeatedly reported by provers. Remedy grade levels would be increased in a step-wise manner according to the number of verifications through clinical application. A grade of 3 indicated clinical verification and a grade level of 4 indicated repeated clinical verification. Boenninghausen did not begin his study of homeopathy until 1828 and published his SRA (containing this four-tier remedy grading nomenclature) a brief four years later in 1832. Yet remedies in the SRA were frequently entered with a grade level of 3 or 4. These initial higher remedy grade levels were often based on the experience of others (Dimitriadis, 2004, p. 63). As Boenninghausen's own clinical experience grew he added further grading modifications to the remedies contained in his repertory.

We've seen that as a rule it takes multiple rubrics to represent well defined symptoms using the Pocketbook. Where a successful prescription resulted in the cure of a particular symptom Boenninghausen would simultaneously upgrade the entire combination of component rubrics in the repertory used to represent the cured symptom. Thus when we look at our Pocketbook analysis chart and find a remedy having the same grade level throughout a rubric combination we've used to represent a symptom, we can interpret this as an indication that this particular rubric combination was successfully used by Boenninghausen himself thus lending an extra measure of reliability to our consideration of the remedy for that particular symptom.

Cumulative clinical experience: remedy concordances

Boenninghausen had realized that a remedy prescribed homeopathically for a particular disease, having effected a change in the totality of symptoms, ‘paves the way’ for the next most (homeopathically) indicated remedy, which, in its turn, works better as a result of the changes effected by the first. Remedies were thus seen, in various conditions of disease, to relate to one another, follow well and complete the action of the former, and these relationships, based on the *similarity* of proving-to-disease symptoms, and further refined via clinical confirmation, were painstakingly recorded by Boenninghausen from very early in his career. (Dimitriadis, 2004, p. 58)

The Concordance chapter maps out the associations between remedies and is the fruit of Boenninghausen’s long years of clinical experience. This final chapter of the Pocketbook is divided into remedy sections. Each section is devoted to a single remedy and they are listed in alphabetic order. You’ll find rubrics corresponding to the major chapters in the Pocketbook plus some additional rubrics not found elsewhere in the repertory. The following rubrics and sub-rubrics appear under each remedy:

- Mind and Sensorium
- Parts of the body and organs
- Sensations and complaints
 - Bones
 - External parts of the body and internal organs
 - Glands
 - Skin
- Change of general state
 - Aggravation
 - Time; aggravation according to the
- Sleep and dreams
- Antidotes
- Related remedies
- Fever, circulation, perspiration etc

This chapter has a number of very useful applications. Consider the situation where we need to change a patient's prescription because the remedy which had previously worked effectively (being then the first correct prescription) is no longer having a curative effect. Our next prescription would be based on the new "current" symptom picture and would include any original symptoms still present along with recent emergent symptom(s) appearing since the administration of the first prescription. Let's say that we had prescribed Lycopodium initially and found that the patient's sleep and bowel symptoms had improved but the skin symptoms had not changed and there were new symptoms related to conditions of aggravation that were not part of the initial picture. In repertorizing the follow up we first select a rubric from the Pocketbook chapter **Concordance of homeopathic remedies** under the remedy Lycopodium for remedies with similar skin symptoms. To this we would add rubrics for the newly emergent modalities now present in the case. This way the focus of the follow up repertory analysis is on those remedies covering the newly emergent symptoms (as per the instructions of Hering) while at the same time being remedies known to have skin symptoms similar to our original prescription, and which appear listed in the rubric **Concordance of homeopathic remedies-Lycopodium clavatum-sensations and complaints-skin**. (Taylor, "Understanding the Boenninghausen Method")

This chapter is most valuable in treating chronic illness where with each successfully prescribed remedy the presenting symptom totality may shift. Guided by its carefully charted remedy relationships we can navigate a succession of prescriptions.

“Most frequently it will be found that in chronic cases which are inveterate, the chief ailment has only been diminished, but still continues, nevertheless when the medicine has completed its action, the concomitant symptoms have suffered such a change that the former remedy will not appear at all applicable any more. In such a case the homeopathic physician can only make a sure selection after having been informed of these changes by a new complete image of the disease. For it is not only taught by experience, but it lies in the nature of all chronic diseases which have in consequence been interwoven with the whole organism, that rarely or never one remedy will cover the whole complex of symptoms; so that it will be necessary in order to destroy the whole malady fundamentally to let several medicines, selected after each report, operate, until nothing morbid may be left.” (Boenninghausen, "Brief Directions for forming a complete image of a disease for the sake of homeopathic treatment: Mental disposition")

You could also use the **Concordance of homeopathic remedies** chapter to suggest alternate remedies for a case where you are unsure of your prescription. Suppose you thought the modalities of aggravation in the case strongly suggested Lachesis but you weren't certain that Lachesis fit the remainder of the case. You could select the rubric in the remedy concordance chapter **Concordance of homeopathic remedies-Lachesis mutas-change of general state-aggravation** and this would give you a list of those remedies with similar conditions of aggravation to Lachesis. You would then add rubrics for the other prominent features of the case. Approaching the repertorization this way the initial field of remedies in the analysis would emphasize those remedies similar to Lachesis in their conditions of aggravation. Or perhaps you are considering a second prescription and several remedies seem to be equally indicated. You would prefer to give a remedy known to follow well after your first prescription, as some remedies are known to act more curatively when preceded by certain other remedies. Using the concordance chapter you could look up your first prescription and check which remedies follow well after it. If one of the remedies you are considering is among those listed, then this would likely be your next prescription. (Boenninghausen, "The Relationship of Remedies")

There is another application for the concordance chapter that I'd like to discuss, one of particular usefulness in studying materia medica. We can use this chapter in the Pocketbook to compare features shared by remedies and also features that distinguish one remedy from another. For example, under the rubric **Concordance of homeopathic remedies-Antimonium crudum-Sensations and complaints** you could select the sub-rubric for skin symptoms. This would give you a list of remedies in the Pocketbook with skin symptoms similar to Antimonium crudum. Selecting a remedy from this list you could do a repertory search for its grade level 3 and 4 symptoms in order to get an overview of features that would help you to distinguish it from Ant-c and also from other remedies having skin symptoms similar to those of Ant-c. We'll take a closer look at this in the next section.

Part VII: Using the Pocketbook in the study of Materia Medica

Throughout this discussion I have referred to Boenninghausen's repertory as either The Therapeutic Pocketbook or just The Pocketbook. This was easier than using its complete title of *The Therapeutic Pocketbook for Homeopathic Physicians for use at the Bedside and the Study of Materia Medica Pura*. The full title suggests that we can employ the Pocketbook as an aid to learning materia medica. I would like to finish off my introduction to the Pocketbook with look at how we might do this.

As students we often try to learn remedies through a kind of single-symptom-single-remedy approach, latching on to a characteristic symptom or two which we use to set one remedy apart from the multitude of others in our minds. We can commit to memory that Sulphur sticks his feet out of the bed, that Pulsatilla is worse in a warm room, that cold perspiration on the forehead belongs to Veratrum album, that Ignatia is for the effects of grief, that arriving too early for an appointment displays the anxiety of Argentum nitricum, that the burning pains of Arsenicum are better from heat...this list could go on and on.

Learning remedies based on a depiction of one or two of their unusual qualities can create a false impression of remedy distinctiveness in our minds. We may come to think of these unusual features as quick routes to finding the simillimum. However, when we study the repertory further we find that some of these idiosyncratic symptoms are not as unique as we first thought they were. Sulphur is not the only remedy that sticks its feet out of the bed covers. There are 21 remedies in the rubric **Extremities-uncover, inclination to, feet** in which Chamomilla, Pulsatilla, Medhorrinum and Sulphur all have a grade level of 3. There are a total of 19 remedies in the rubric **Mind-anxiety, time is set, if a**, indicating that Argentum nitricum shares this particular mental quality with many other remedies. Pulsatilla appears as one of 140 remedies in the rubric **Generals-warm room agg**; and Ignatia shares the rubric **Mind-ailments from grief** with no less than 92 other remedies. In truth remedies have a lot more in common than they have differences. A single unusual symptom, even if it is a keynote symptom, is seldom enough to base a prescription on and requires the support of the rest of the symptom totality.

In the chapter **Concordance of homeopathic remedies** Boenninghausen shows us that remedies have a great deal more in common than a quick study of the Materia Medica reveals. This overlapping of symptoms means that in the homeopathic diagnosis the uniqueness of a case most often rests on a *combination* of its consistent characteristic features and not on any single feature. Stripping homeopathic diagnosis of all of its hype and mystique we are left with Hahnemann's guiding words "Let likes be cured by like" and which Joe Kellerstein's phrase "homeopathy is pattern matching" encapsulates perfectly. (Kellerstein, "Just What Exactly is Characteristic and Peculiar in Homeopathy? A discussion of the Centrality of Homeopathy - Aphorism 153") Our study of materia medica can begin then with a focus on the reliable symptom patterns of remedies.

The Therapeutic Pocketbook rubrics derive from the most characteristic symptom features of the provings. They are already organized for us according to remedy locations, sensations and modalities. In these rubrics remedies appearing with grade levels of 3 or 4 have been verified through Boenninghausen's extensive clinical experience. The Radar homeopathic software has a search feature that can be used to retrieve rubrics from the repertory for an individual remedy or several remedies simultaneously. This "comparative extraction" feature (pressing F5 starts it) is extremely effective when used with the Pocketbook. Let me illustrate with another example.

Dimitriadis has said that symptom modalities represent the "core" of a remedy. (Dimitriadis, 2004, p. 52) From the Pocketbook's concordance chapter I can look up Pulsatilla and the rubric **Concordance of homeopathic remedies-Pulsatilla pratensis-related remedies**. In this rubric Lycopodium is listed with a grade level of 4. Boenninghausen is indicating with this high grading that these two remedies have been repeatedly found to share many similar features. Now we can use Radar's comparative extraction feature (press F5) to give us a list of the grade level 4 conditions of aggravation and of amelioration for both Lycopodium and Pulsatilla. This will allow us to see their similarities and differences at a glance. Examining two remedies in this way deepens our knowledge of both; through first relating them on their commonalities, and then distinguishing them on their differences. I've printed the extraction of grade level 4 modalities for Lycopodium and Pulsatilla on the following page.

Modalities (grade level 4) shared between Lycopodium and Pulsatilla

1. Change of general state - Aggravation - time; according to the – afternoon
2. Change of general state - Aggravation - time; according to the – evening
3. Change of general state - Aggravation - time; according to the - midnight – before
4. Change of general state - Aggravation - rising from sitting – when
5. Change of general state - Aggravation - motion; from - beginning of motion; at
6. Change of general state - Aggravation - walking - beginning to walk; when
7. Change of general state - Aggravation - urination – during
8. Change of general state - Aggravation - lying; while
9. Change of general state - Aggravation - lying; while - bed; in
10. Change of general state - Aggravation - menses – before
11. Change of general state - Aggravation - menses - suppressed; from
12. Change of general state - Aggravation - lying down; after
13. Change of general state - Aggravation - rest; at
14. Change of general state - Aggravation - sitting; while
15. Change of general state - Aggravation - warm air; in
16. Change of general state - Aggravation - warm; when becoming - air; in open
17. Change of general state - Amelioration - rising - sitting; from – after
18. Change of general state - Amelioration - motion; from
19. Change of general state - Amelioration - flatus; after discharge of
20. Change of general state - Amelioration - cold; when becoming

Modalities (grade level 4) Lycopodium without Pulsatilla

1. Change of general state - Aggravation - alone; being
2. Change of general state - Aggravation - eating - after - satiety; after eating to
3. Change of general state - Amelioration - eructations; from
4. Change of general state - Amelioration - company; in
5. Change of general state - Amelioration - warm; when becoming - bed; in

Modalities (grade level 4) Pulsatilla without Lycopodium

1. Change of general state - Aggravation - breathing - expiration; during
2. Change of general state - Aggravation - motion; from - after motion
3. Change of general state - Aggravation - quinine; from abuse of
4. Change of general state - Aggravation - twilight (in the evening); in the
5. Change of general state - Aggravation - frostbite; from
6. Change of general state - Aggravation - food and drinks; from partaking certain – bread
7. Change of general state - Aggravation - food and drinks; from partaking certain – butter
8. Change of general state - Aggravation - food and drinks; from partaking certain - bread and butter
9. Change of general state - Aggravation - food and drinks; from partaking certain – buckwheat
10. Change of general state - Aggravation - food and drinks; from partaking certain - fat food
11. Change of general state - Aggravation - food and drinks; from partaking certain - frozen food

12. Change of general state - Aggravation - food and drinks; from partaking certain – pancakes
13. Change of general state - Aggravation - food and drinks; from partaking certain - pork; (fat)
14. Change of general state - Aggravation - food and drinks; from partaking certain – tobacco
15. Change of general state - Aggravation - food and drinks; from partaking certain - warm food
16. Change of general state - Aggravation - food and drinks; from partaking certain - wine - sulfurated [wine to which sulfur was added]
17. Change of general state - Aggravation - urination – before
18. Change of general state - Aggravation - scratching; from
19. Change of general state - Aggravation - lying; while - low; with head
20. Change of general state - Aggravation - measles – during
21. Change of general state - Aggravation - measles – after
22. Change of general state - Aggravation - rubbing; from
23. Change of general state - Aggravation - sun; in the
24. Change of general state - Aggravation - women; especially in
25. Change of general state - Amelioration - moistening affected part; from
26. Change of general state - Amelioration - food and drinks; from partaking certain - cold food
27. Change of general state - Amelioration - lying; while - high; with head
28. Change of general state - Amelioration - washing; from

There are 20 (grade level 4) modalities held in common between Pulsatilla and Lycopodium. The others are either found in Lycopodium but not Pulsatilla, or in Pulsatilla but not Lycopodium. Given a case which had one, or more, of the modalities not common to Lycopodium and Pulsatilla we could use that modality to reliably differentiate between the two remedies. Using Radar’s remedy extraction feature (F5) you can also produce similar lists of the clinically verified sensations and locations for each remedy in the same way.

This method of study begins where our materia medica begins, with the provings. To this we would then add the second branch of experiential knowledge about our remedies – their accumulated clinically derived experience – by studying the works of such respected homeopaths as Hering, Lippe, Nash, Allen and Dunham. The charts that follow contain a concise summary of these Pocketbook comparative extractions for Lycopodium and Pulsatilla.

Modalities of aggravation (Grade level 4)

Lycopodium

Afternoon, evening, before midnight
Sitting, rising from sitting
On beginning motion; beginning walking
During urination
While lying, lying in bed, after lying down
Before menses, suppressed menses
While at rest
Warm air, becoming warm
Being alone
After eating to satiety

Pulsatilla

Afternoon, evening, before midnight
Sitting, rising from sitting
On beginning motion; beginning walking
During urination
While lying, lying in bed, after lying down
Before menses, suppressed menses
While at rest
Warm air, becoming warm

During expiration
Motion, after motion
Abuse of quinine
Twilight
From frostbite
Bread, butter, buckwheat, frozen food, pancakes, pork (fat), tobacco, warm food,
Wine (sulphurated)
Before urination
From scratching
Lying with the head low
During and after measles
From rubbing
While in the sun
Aggravations in women

Modalities of Amelioration (Grade level 4)

Rising from sitting
Motion
Discharging flatus
Becoming cold
Eructations
Becoming warm in bed
While in company

Rising from sitting
Motion
Discharging flatus
Becoming cold

Moistening the affected part
Cold food
Lying with the head high
From washing

Sensations (Grade Level 4)

Lycopodium

Chlorosis
Tearing (drawing) internal parts in
Consumption, phthisis, in general
Tension – joints; in the
Tension – internal parts; in
Skin – colour on the skin – pale
Skin – ulcers – general; in
Skin – ulcers – fistulous (fistulae)
Skin – ulcers – hard
Skin – itching – general; in

Cramp like sensation in muscles
Contortion of limbs, drawing into bent position
Skin eruptions oozing
Skin, wet skin oozing (discharge of moisture)
Skin, tetters, oozing
Skin, ulcers, indolent (without special sensation or pain)
Skin, corns, pressing pain; with
Skin, corns, tearing pain with
Skin, itching-creeping (running like an insect)
Skin, itching-scratching; after oozing (discharge of moisture)
Skin, sticky

Pulsatilla

Chlorosis
Tearing (drawing) internal parts in
Consumption, phthisis, in general
Tension – joints; in the
Tension – internal parts; in
Skin – colour on the skin – pale
Skin – ulcers – general; in
Skin – ulcers – fistulous (fistulae)
Skin – ulcers – hard
Skin – itching – general; in

Growling (roaring, humming, buzzing) in body
Ulcerative pain, external parts in
Ulcerative pain, internal parts in
Gout-like jumping pains, wandering (quickly shifting)
Stitching, tearing (drawing), muscles in the
Ulceration, festering pain; pain as from subcutaneous
Labour-like pains
Choking pain
Dragging, hard pulling, tugging sensation
Bruised pain; as if – joints of the

Glands – swollen sensation
Skin, eruptions – measles; like
Skin, eruptions – rubella, German measles
Skin, eruptions – chickenpox, varicella
Skin – chilblains – blue
Skin – ulcers; ulceration, festering pain; as from subcutaneous
Skin – ulcerative pain in the skin
Skin – swelling – bluish black
Skin – swelling – stitching pain with
Skin – swollen sensation
Skin – itching – scratching – unchanged by
Skin – itching – scratching agg.
Skin – nails – ulcerative pain; with

In Summary

Boenninghausen's Therapeutic Pocketbook fell into disuse long ago. The more popular repertoires of Synthesis and The Complete offer a seemingly greater coverage of the details of our Materia Medica and include a far greater number of remedies. For students of homeopathy the perceived need to have more remedy detail in the repertory is a compelling one and this is all the more tangible now that these two repertoires have become computerized. Using this software we can quickly search the entire repertory or countless pages of Materia Medica within minutes, accomplishing what homeopathy's forefathers would have taken entire evenings to achieve – all done without the diligence and focus that, in an earlier time, would have allowed the exercise to become permanently ingrained in our minds.

The early employment of these labour saving programs can lead students into a labyrinth of repertory specifics the details of which may eclipse those distinguishing remedy themes on which prescribing depends. This can result in a classic instance of not being able to see the forest for looking at the trees. As a counter balance to the bewildering surplus of remedy detail found in computerized repertoires Boenninghausen's Therapeutic Pocketbook stands as an unparalleled achievement, both at the time of its publishing and still to this day. It is a systematic and thorough analysis of 125 remedies that draws together their common features, characteristic qualities and clinically verified application. Through the brilliance of its unique design it embodies the remarkable insights of one of homeopathy's great prescribers. In due time and with practice we can learn to apply these same insights to our own case analysis and our study of Materia Medica.

Appendix A: Boenninghausen-like repertorization

Homeopathic students incur a lot of expenses between tuition, travel, and the purchase of the required text books. There are also an increasing number of students using computer software early in their studies. Software for the PC user such as Radar does not come cheap and to suggest that students purchase the Boenninghausen module would just add to the financial burden students bear at the start of their studies. Though Synthesis is not set up like the Therapeutic Pocketbook we can still apply the wisdom contained in the Pocketbook's design to our use of Synthesis. Here are some suggestions for future repertory work:

1. A case will most often rest on the distinctiveness of its combined consistent features. When it comes to selecting which symptoms we are to include in the analysis, consistency of presentation is a more valuable criterion than rareness. Modalities are the most reliable aspects of the provings and consequently the best guide to selecting a remedy. Recurring sensations and modalities are “genius” symptoms of the case and form the core of our diagnosis. In Synthesis we can find rubrics for generalized modalities in the Generals section of the repertory.
2. Your analysis is only as inclusive as your smallest rubric. Larger rubrics preserve the field of potential remedies and should be used whenever possible. Synthesis now includes a number of Boenninghausen entries in its more general level rubrics. Additionally, setting the repertory option to “Full Synthesis, rmd copied” adds all remedies found in smaller sub-rubrics to the main parent rubric ensuring that they will be included in the analysis when the larger rubric is selected.
3. The mental/emotional case is comprised of symptoms since the onset of the earliest known occurrence of illness. Like all other symptoms they must have consistent presentation. Symptoms of the mind are difficult ones to repertorize often being subject to the most speculative interpretation on the part of the homeopath. In selecting rubrics for the mental/emotional case we should err to the side of caution, avoiding small seemingly exact rubrics as they often eliminate too many remedies. The repertory is not the tool to use for remedy differential diagnosis. A careful study of the materia medica remains the only way to get a clear mental picture of the remedy(s) under our consideration.

Appendix B: our repertory lineage

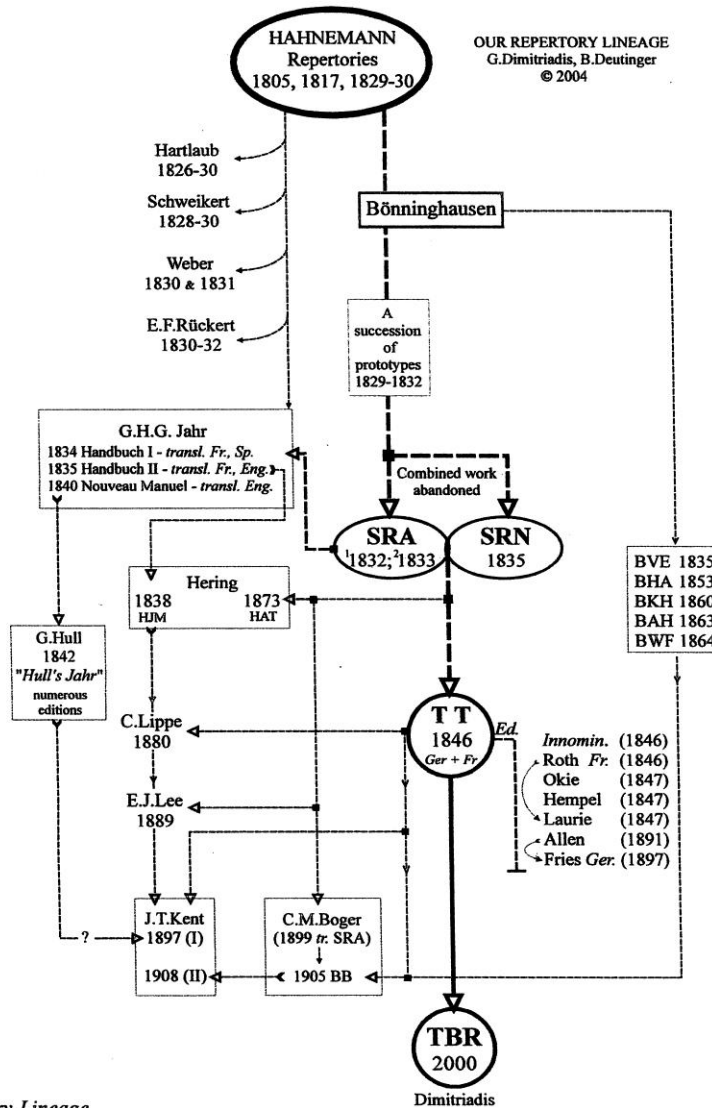

Our Repertory Lineage

The lineage of TBR is directly through TT which itself had undergone a number of republications, beginning with the *innominate* English edition of 1846, and ending with the *TF Allen* edition of 1891 and its later re-translation into German (Fries, 1897). Note the English edition of *Laurie* was translated from the French translation of *Roth*, and not directly from the German original. *Hering et al.* translated the inferior work of Jahr (*Handbuch II*) into *Jahr's Manual...* (HJM, 1838), rather than having gone directly to Bönninghausen (SRA/SRN - upon which Jahr based his own work). Hering later realised the unmatched value of Bönninghausen's clinical work, and used it as a sole basis for his *Analytical Therapeutics* (HAT, 1873). Kent's Repertory received input from various (non-primary) sources, most directly through Lee, and later, Boger (BB), for which Boger claims to have translated all of Bönninghausen's previous works (BVE, BHA, BKH, BAH, BWF - refer bibliography for details).

THE BÖNNINGHAUSEN REPERTORY
Therapeutic Pocketbook Method

George Dimitriadis

BSc.(UNSW), DHom.(Syd), DHomMCCH(Eng), MBöAG(Ger), LiRF(HISyd)

Hahnemann Institute, PO Box 1408, Parramatta NSW 2124, Sydney, Australia

Summary

Expanding on our earlier introductory comments within this Journal,(1) we herein demonstrate the application of Bönninghausen's unique *repertorial method* both *wholly & solely* encapsulated within his *Therapeutisches Taschenbuch* (TT),(2) utilising our English language TT republication, *The Bönninghausen Repertory* (TBR),(3) with case examples successfully treated using TBR alone, thereby highlighting its simplicity, accuracy, and depth of therapeutic scope.

Using TBR

The exclusive application of TBR(4) in my own practice for over four years,(5) coupled with our more recent examination of Bönninghausen's earlier repertories,(6) have together provided valuable insight towards the most efficient application of this method in the clinical situation. Whilst it is not possible (nor is it my purpose) within these few pages, to thoroughly examine and discuss the method and its effective application using our TBR,(7) the following case studies(8) are nevertheless offered as a follow up to my earlier article,(9) as examples of the case analysis, the use of TBR, and the effectiveness of the method in the treatment of chronic cases.

Terminology

Presenting (main) complaint: That complaint(10) which is the most bothersome and/or for which the patient seeks treatment. Sometimes, the patient seeks treatment for a less significant complaint, simply because they believe their other complaints are not able to be helped, or they are unaware of the gravity or urgency of other discernible signs, and the practitioner must determine which complaint in each case is to be considered as the focus of treatment.

Concomitant complaint: All other complaints co-existing with the presenting complaint. Concomitant complaints may be seen in syndromal relationship to the presenting complaint. In a chronic case which develops over a longer term, the concomitant complaints may even pre-date the main or presenting complaint for which the patient seeks treatment.(11) Their connection to the main illness may be established without doubt when a single remedy covers both the main and the concomitant complaints.(12) Concomitant symptoms wherever present, must be considered for a case to be regarded complete.

As far as is possible, a *complaint* (collection of presenting or concomitant symptoms) must be defined by its specific *location*, and *modalities* (which must themselves be characteristic (consistent)).

Cases

1. *Plantar wart*

MD, 31 years, female, full-time mum. Presented with a single very large and very deep plantar wart on her left sole, in the region of the ball of the foot (between digits 2-3) which had been growing slowly over the previous 6-7months. Surgery was advised but without promise of either success (high incidence of recurrence after surgical excision), or that no neural deficit would result from the surgery in such a sensitive, nerve rich region.

Symptoms: Plantar wart, around 2cm diameter, with a very thick core and very sensitive to pressure. The wart looked more like a very thickened stratum corneum without visible roots, and the centre was particularly thick and hard (hyperkeratotic). The wart was at times painful *per se*, a sharp pain, which was particularly exacerbated if standing on the part, especially on a hard surface (a rock, etc). Generally feels unwell in hot weather, or if becomes overheated (through exertion etc.) No other ascertainable symptoms. Rubrics:

TBR358 Foot, Sole + TBR1908 Skin, Warts, Horny + TBR1916 Warts, Stitching

TBR2668 *Aggr.* Walking, on cobble-stone (stone pavement, uneven surface)

TBR2099 *Aggr.* Warm air, + TBR2104 *Aggr.* Warm, heated, becoming

Whilst the concomitant complaint modalities relating to a general feeling of being "unwell" were not necessary for the homœopathic diagnosis (remedy selection) in this case, they have been included to demonstrate the depth of coverage of this remedy for the whole process of illness in this case. Hahnemann's MMP (*Materia Medica Pura*) confirms our choice with the following clear descriptions:

Ant-c.CK/CD386 “Great sensitiveness of the soles of the feet to walking, especially on stone pavements...”

Ant-c.CK/CD387 “Large horny places on the skin of the sole of the foot, near the beginning of the toes, paining like corns, and always returning after being cut out.”

Ant-c.CK/CD409 “He feels ill in the heat of the sun and the warm air, even with light motion and work.”

Indeed, there could be no better description for this patient’s plantar wart, and quickly revealed by using the TBR to simply combine the characteristic components which precisely define the complaint.

Rx: Ant-c 30 (L) b.d.(13) Three weeks later she reported a marked improvement in the pains - she can now stand on that foot without discomfort (even on hard surfaces), also able to walk normally, and for long periods without difficulty. No stitching pains per se. On examination, the “wart” measured around half its original size, and the central core was slowly exfoliating to reveal a softer base. *Rx: Ant-c 30 (L) b.d.*

4 weeks later: almost no visible “wart” – just an area of hardened skin. Still some pain if standing on hard surface (esp. on a rock etc.).

Rx: Ant-c 30 (L) b.d. to continue

4 weeks later: Hard centre of old wart area fell off. Now the area is flatter, and smaller. No real pain - just some discomfort experienced after prolonged standing - not even painful if walks over a rock. Very happy with results. *Rx: Ant-c 30 (L) b.d. to continue.* Patient was discharged 1 month later and has not returned.

2. Remittent Cough

C.T., 3 years, female. Presented 13 March 2002 with history of remittent cough since a severe attack of acute bronchitis 2 years earlier which was associated with violent cough ending only after vomiting. The (now dry) cough, which is associated with heat all over body, comes in episodes which increase in violence, yet even between episodes, she is never quite free of cough. She is particularly worse during the winter months and sleeps with head elevated which helps settle the cough. Pitiful when sick. Rubrics taken:

TBR736 Cough, expectoration, without + TBR1404 Generals, Spasms

TBR2111 *Aggr.* Winter + TBR2453 *Aggr.* Lying with head low

These rubrics sufficiently defined the remedy for this case. *Rx: Puls.30 (L) o.m.*

03 April 02: For first 4 days of taking medicine, coughed up lots of green mucous. Since then, has had no cough. No fever. Looks well. Lungs clear on examination. *Rx: Puls. 30 (L) o.m. to continue.*

24 April 02: Remains well. No signs of any problems. Parents very happy. *Rx: Puls 30 (L) o.m. to continue.*

Note the rubric TBR1404 (Generals, Spasms) refers to spasmodic (episodic) phenomena, not simply to muscle spasms (which may be found under the section on *muscles*). Whilst there were other features which could have also added to the repertorial consideration (eg., TBR2658 *amel.* after Vomiting; TBR2353 *aggr.* during Heat [concomitant to the cough episode]), the rubrics selected pointed out the main contenders, which could easily be further distinguished without repertorial aid. It is best to remember that the repertory, any repertory, is merely an aid, and the final selection must be based upon the data of provings.

3. Recurrent Cough

L.C, 8 years, male. Presented 6 June 2002 with history of recurrent coughs, which would come each winter. At 12 months of age, was diagnosed with asthma (parents stopped all inhalors over 2 years ago). Condition begins with cough at night, and usually persist all winter. Other symptoms: epistaxis for no reason, since last few years; poor comprehension – at times, can’t even seem to understand a simple question such as “where are you going”, or “where is your jacket” – seems confused and as if his brain just doesn’t function. He is very embarrassed about this, especially at school where he is doing poorly. Rubrics:

TBR2111 *Aggr.* Winter (PM) + TBR143 Epistaxis (CC) + TBR1069 Comprehension difficult (CC)

Note: The aim in each case is to use the least possible number of rubrics, since the repertory is only used as a pointer to the materia medica, which may then be consulted for the remedy selection. These three rubrics provided me with sufficient direction, being sufficiently familiar with the respiratory symptoms of this remedy in Hahnemann’s MMP, to make my selection quickly. *Rx: Rhus-t. 30 (L) o.m.*

05 July 02: Cough much better. No epistaxis. Comprehension seems better also. New symptom: Pain in penis after urination. *Rx: Rhus-t 30 (L) o.m. to continue.*

02 August 02: No cough. No epistaxis. Comprehension great. *Rx: Rhus-t 30 (L) 1 dose every 2nd day.*

I treat the whole family, and the parents recently reported (April 2003) this child remains cough free and comprehension remarkable, even the teachers have commented. No other symptoms.

Notes:

1. In this case that the individuality of this case was sufficiently distinguished by the presenting symptom modality coupled with two concomitant complaints. It is, as Bönninghausen stated, most often that the *combination* of characteristic (though individually not sufficiently distinguishing) symptoms of a case, which itself provides the necessary distinction. The separation of areas affected (respiration, nose, mind), in this single case provided a sort of triangulation to zero in on its specific remedy, without the necessity for finer detail being explored in each particular area.
2. Whilst the new symptom reported at the second consultation fitted well the symptoms of *Rhus.*, (*Rhus.MMP465* “Great smarting on the front part of the urethra, continuing during and after micturition...”, *MMP466* “...smarting in the urethra, during and after micturition.”), nonetheless, it was not disturbing enough (to the patient) to warrant a change in the prescription. It is not uncommon to observe such minor new symptoms appear during the course of treatment in chronic cases, however, they are often transient, and will disappear without further attention. Only when they persist and now significantly affect the patient do they demand our attention.

4. *Impetigo*

S.S-L., 11 years, female. Presented April 2002 with a diagnosis of impetigo which had begun 6 weeks earlier as a single lesion at left corner of mouth, thought to be a cold sore. But gradually lesions appeared in various places over the body. Lesions were themselves striking – with large (2-3cm) main eruptions surrounded by a circle of smaller vesicles at its perimeter. The other striking feature was that only the left side was affected – left arm, left leg, left corner of mouth, even left side of trunk – a few lesions approached but stayed to the left side of her navel. Rubrics taken:

TBR1964 Ulcers, blisters around, with + TBR1185 Sides, Left.

Rx: Lach. 0/1 t.d. down to b.d. (with improvement). Mother reported back 5 days later with “great improvement” – no new lesions, old lesions drying and getting smaller. Skin completely clear after 2 weeks. Still no recurrence after three months.

It is uncommon for to require or depend upon “sides” in a case of illness, since symptoms must appear somewhere; but a particular side, or locality, may indeed be considered significant when, in a fully developed disorder, it remains the consistent focal point. This case was clear in that the lesions approached, but did not cross the midline, even though the condition had ample opportunity to do so over the previous 6 week period of its existence. Note also that the exact description of the eruption was instrumental in defining the nature of the illness for the sake of reaching a homœopathic diagnosis (remedy selection).

5. *Chronic sinusitis*

MM, 39 years, female, horticulturist: Presented in November 1998 with recurrent sinusitis for many years, with ‘searing’ pains in, and puffy swelling of the cheeks, with a feeling of fullness (congestion) in the face, and accompanied by some yellowish/greenish nasal catarrh. The facial pains would, at their worst, extend into the teeth, were worse on the left side, and < lying on that (painful) side (which increased the fullness sensation and puffiness in the cheek lain upon). The pains were typically *aggr.* noise, light, strong odours (even of coffee), heat, but especially reproducible by a *loss of sleep*, to the point that she would leave an engagement or function early, in order to ensure a sufficient length of sleep.

She had a history of migraines (still quite frequent at presentation) since the age of 8 years, and extensive diagnostic investigations were clear. The pain often was focused behind one (usually the left) eye, and was preceded by black floaters (*muscae volitantes*). Also in the history, 2 years earlier, she had an endometrial ablation due to *very frequent and profuse menstrual flow* (with clots), accompanied by lower back pains and swelling of the vagina & vulva region. The rubrics taken for the case were:

TBR716 Coryza, obstructed
TBR2459 Aggr. Lying painful side
TBR 2599 Aggr. Sleep, loss of

These above rubrics combined to cover the presenting (main) complaint. Hahnemann’s MMP provided the confirmation necessary for the prescription in such a persistent and inveterate illness:

MMP635-646 (coryza)
MMP186-219 (teeth & jaw pains)
MMP103,107,110 (swelling of cheeks)
MMP1095-7 (persistent nasal obstruction)
MMP147 (floaters in field of vision)
MMP602 (swelling of the vagina)

Rx: Nux-v. 30 (liquid) b.d. She reported back by telephone 2 weeks later, that she had some aggravation initially, but after 2-3 days her sinusitis (fullness in the head and face, etc.) had completely vanished within 3 days. She cancelled her follow-up appointment.

July 2000, she again consults me, but this time for her migraines, which have gradually become more uncomfortable - no return of her sinusitis (head feels completely clear). On examining the symptoms of her migraines, they were unchanged

from her previous record, the worst modality being the *loss of sleep*. She also complains about her weight-gain over the past few months, due to the fact that she has had an uncontrollable desire to eat, and usually junk food.

Apart from the symptoms already covered by *Nux vomica*, the profuse menstrual flow (TBR645) and the voracious appetite (TBR376) are well covered by the original prescription. The following symptoms from MMP are noteworthy for this case:

MMP25 “In the morning, headache as if he had not slept enough”

MMP43 “Aching pain in the forehead, as if he had not slept enough”

MMP44 “Aching pain over the left eye”

MMP45 “Aching pain over the right orbit...when he lies on the right side, ...going off when he lies on the opposite side”

MMP604-610 (Menses too frequent)

Rx: Nux-v. 30 (liquid) o.m. Returned 8 September 2000 reporting “I feel very well”. She has had only 4 migraines since beginning the remedy, and each time it was triggered by late night functions (which she has frequented more often, due to the improvement in her condition). Her sleep quality is better – waking without that dull head. Also, a long-term easy tendency to gagging (on brushing teeth, unpleasant odours, etc) has markedly diminished.

6. Chronic palmar dermatitis

JE, 50 years, female, bank teller. Presented 25 October 2000 with dermatitis, affecting the hypothenar eminences and extending to the palmar surface of both hands. The affected areas were marked by hard desquamations (hard flakes of skin) which had to be picked-off, exposing a painfully raw surface beneath. Patient linked the onset of this condition with the onset of her menopause (3 years earlier). Other symptoms:

Sinusitis: frequent and severe, at worst times with strong pains extending over the face

Feeling of ‘lightness’ in the legs at night in bed (almost every night)

This case was fairly straightforward. The *presenting complaint* was identified in the location, TBR329 Palm, and nature of the complaint clearly described under TBR1775 Eruptions, Hard. The combination of concomitants was equally defining: TBR716 Obstructed coryza + TBR1311 Lightness feeling in the limbs. Even though there were no striking modalities, the combination of other (lesser) characteristics proved sufficient to identify the remedy for this case. *Rx: Spig. 30 (L) o.m.*

November: Hands improved, the patient reporting that there was less peeling and less need to pick at the hard flakes. No return of the lightness sensation in her legs. Interestingly, her ankles, which were constantly swollen since the age of 14 years (which she had not mentioned to me before), and for which she had been on diuretics (*Moduretic*) all that time, have also improved. *Rx: Spig. 30 (L) o.m.*

December: Hands much better - still peeling, but look much smoother and flakes of skin are not so hard. Feeling much better in herself. Ankles still less swollen. No sinusitis. *Rx: Spig. 30 (L) o.m.*

This case continues to do well on infrequent doses of *Spigelia*, with intercurrent *Pulsatilla* when a change of symptoms demanded it (anxiety + weepiness + concordances (14) to *Spigelia*).

7. Aggressive psychosis

S.T., 14 years, female: Presented 10 August 2001 with severe emotional disorder which seemed to date back to her having been “bashed” 12 months earlier (also coincided with menarche, and relationship breakup). Symptoms have become worse over the past 6 weeks or so, and no menses since 2 months. Becomes depressed, angry, suicidal. Feels as if “crazy” – talks aloud to herself and hears voices; becomes threatening with lots of foul language (“fuck”, “cunt”, “shit” etc.), and very aggressive, striking out in anger – wants to hurt people and break things. Not scared of anyone any more – certainly not of any authority. This girl was now feared by her friends at school, and the parents were at a loss to know what to do, and psychiatry had not improved things. Rubrics taken:

TBR1054 Maliciousness + TBR1040 Audaciousness + TBR1074 Insanity (madness in general; *Psychoses*)

TBR642 Menses, suppressed (amenorrhœa)

As the repertory confirmed, this case evidenced a clear picture of a *Veratrum album* psychosis. *Rx: Verat. 30 (L) o.m.*

01 Sept. 01: Better in general – not so “wild”; not so “rude” or “vulgar”. Not hearing any voices, and is now not carrying on conversations with herself. *Rx: Verat. 30 (L) o.m. to continue.*

29 Sept. 01: Had been O.K., but had a “breakdown” and went backwards again. *Rx: Verat. 200 (L) o.m.*

03 Nov. 01: All going well – no dramas. *Rx: Verat. 200 (L) o.m. to continue.*

01 Dec. 01: All fine. Feeling and doing really well. Doesn’t feel that wildness nor the need to hurt anyone. Wants to be good and do the right thing. *Rx: Verat. 200 (L) one dose every 2nd day.* This dosage schedule was explained to the father as a precursor to complete withdrawal from treatment by the time the medicine was used up, but to contact me should symptoms begin to recur. I have not been contacted.

In his MMP preamble to *Veratrum album*, Hahnemann states: “Physicians have no notion of the power possessed by this drug to promote a cure of almost one third of the insane in lunatic asylums... because they know not the peculiar kind of insanity in which to employ it...” Note the concomitant amenorrhoea was also useful in confirming the remedy selection.

Concluding remarks

As with any repertory, an understanding of the precise meaning of rubric terms is the key to its most effective and efficient use, and this is particularly the case with this repertory whose rubrics are very summarised representations of the materia medica and generally broader in their scope than with other works. Whilst some cases require 5 or 6 rubrics to adequately define their scope, most often only 3 or 4 rubrics (or less) are sufficient.

This fundamental process of understanding rubrics requires a careful and methodical reference to the source materia medicæ (provings) in their original language, and whilst slow and difficult, our own work in this regard over the past few years has not only proved invaluable for our clinical work, but sadly, revealed the many and repeated errors of both omission and comprehension, based partly on a lack of care, and partly on assumptions with regard to meaning by translators without due reference to original sources for an accurate and contextual clarification.(15)

Lastly, these few cases show that the repertorial method of Bönninghausen, through its representative TBR, is applicable to chronic inveterate illness as well as to acute.(16) In fact, this method lends itself more particularly to the treatment of multi-system chronic disorders,(17) where a consideration of the (precisely defined) complaints in their combination is most often required for the homœopathic diagnosis, for which purpose this repertory, from concept to construct, provides a unique and unsurpassed mechanism.

notes

- 1 AJHM. Vol. 96, No. 2., Summer 2003.
- 2 Bönninghausen’s TT first appeared in 1846 (Münster), being quickly followed by its English translation *Therapeutic Pocketbook* (TPB) completed in the same year. Refer earlier article for the various English language editions.
- 3 G.Dimitriadis (Ed.): The Bönninghausen Repertory – Therapeutic Pocketbook Method, Hahnemann Institute Sydney, June 2000. This book may be obtained by contacting theborep@nextcentury.com.au
- 4 To avoid any confusion, it must be stated that the recent “Bönninghausen Repertory” computer programme produced (within a 5-month period) for the *Radar* platform (without reference to the provings for clarification of rubrics), and whose name too closely resembles that of our own work, bares no relation to our TBR (which required 5 years of work for its completion).
- 5 We had been trialing our TBR manuscript in practice for over 18 months prior to publication.
- 6 *Systematisch-alphabetisches Repertorium der Homöopathischen Arzneien. Erster Theil, enthaltend die antipsorischen, antisymphilitischen und antisymphilitischen Arzneien* [Systematic Alphabetic Repertory of Antipsoric Remedies...{SRA}], 1st ed. 1832; 2nd ed. 1833; *Systematisch-alphabetisches Repertorium der Homöopathischen Arzneien. Zweiter Theil, enthaltend die (sogenannten) nicht-antipsorischen Arzneien* [Systematic Alphabetic Repertory of the (so-called) Non-Antipsoric Remedies {SRN}], 1835. Our group at the Hahnemann Institute in Sydney are now examining Bönninghausen’s TFR work, to locate errors of typography, language, duplication, omission, etc., for the purpose of republication of a single work: *The First Repertory* (TFR).
- 7 Refer TBR Introduction on *How to Use this Repertory* for a more detailed account of the method.
- 8 These cases were amongst those presented at seminars on the Bönninghausen method in Sydney, Auckland, and Wellington.
- 9 The concepts outlined in that article should be kept in mind by the reader when studying these cases, in particular with regard to the concept of a complete symptom and precisely defined complaint.
- 10 To remind the reader of my previous article, by ‘complaint’ I mean a collection of symptom components (sensation/finding, location, modality/ies) which together render the symptom complete (complaint; identifiable condition).
- 11 Suffice it here to say that disease is best understood as a process (not simply an event) which develops, less or more rapidly, over time and may influence various systems and organs. In chronic disorders, the final pressing symptoms for which a patient presents may indeed be simply the end result of a long and convoluted process of disorder expressing itself through series of symptoms, some of which may have disappeared, either spontaneously or with the help of relieving medications etc., but which nonetheless reflected the single process of disorder.
- 12 When a single remedy which covers both the presenting complaint and the concomitants can not be found, then the presenting complaint usually forms the focus of treatment. The only exceptions will be when the presenting symptoms are ill-defined (incomplete), and/or the concomitants so strongly distinguished as to their singular character, that the remedy may be then decided on them alone.
- 13 For many years now, after having carefully studied the writings of Hahnemann on the matter, I have adopted a particular approach wherein both *Centesimal* and *50 Millesimal* (‘0/’ or ‘Q’) potencies are given in the same manner, without presumption of potency-based effect variance. Only in this way can we then attribute any differences to potency alone. This has provided some important conclusions for my own practice, but this is not the place to expand on that topic.
For dispensation purposes, I label my liquid preparations (centesimal potencies) with the suffix (L), in order, firstly, to distinguish it from the so-called ‘radionically prepared potencies’, and secondly, to indicate they are not precisely the potency from the manufacturing pharmacy (say, 30 centesimal), but rather, the solution of two globules into a specific amount of liquid, succeeded prior to administration.
- 14 This most helpful chapter on the concordances developed by Bönninghausen, is as simple to use as it is brilliant in its conception and utility. Whilst this is not the place to expand on the matter, that it has been too often completely misunderstood can be evidenced by A.H. Okie, in his 1847 English language TPB, was so ignorant as to have omitted it, brazenly stating “As this is a subject upon which, at the present, we have but little experience, and as the author’s concordances seemed to offer nothing new or of a really practical nature upon this subject, I have omitted it...”). But, as I have myself discovered and shown at my seminars, it is not too difficult a task to comprehend

the construct and application of this chapter (even though Bönninghausen did not leave any particular direction in this regard), and the results speak for themselves.

- 15 Our work on the TFR of Bönninghausen has been even more revealing in this regard, and has uncovered unexpected mistakes of past (even well-known) authors which must, at all cost, be avoided in any future work. It is our intention to present our findings with the republication of the TFR. It is to be noted that these errors have not only been reproduced within republications of old works, but are being added-to by present day translators who not only fail, but consider it unnecessary, to consult the original sources before deciding on meaning. Specific examples from familiar modern works may form the subject of another article.
- 16 It is simply an error to assume that the method is suited mostly or only to the acute or one-sided diseases.
- 17 My own practice and that of my close colleagues see mostly such chronic cases (including so-called ‘mind’ disorders). Because our system of therapy is not covered by our ‘Medicare’ national health scheme, patients usually seek our help as a last resort, after having been elsewhere (usually to many physicians and medical specialists). These patients often have a long history of treatment (allopathic, including herbal, naturopathic, chiropractic, etc.), dietary, and other changes in an effort to get better, and our experience even in these cases shows not only the effectiveness of the well selected homœopathic remedy (over and above the patient’s other medications), but also the simplicity and speed of prescribing using TBR.

submitted *AmJHomMed* May 2003

Bibliography

- Boenninghausen, C. v. "Atropa Belladonna". In Radar, *Encyclopaedia Homeopathica*. Archibel.
- Boenninghausen, C. v. "Brief Directions for forming a complete image of a disease for the sake of homeopathic treatment: Mental disposition". In Radar, *Encyclopaedia Homeopathica*. Archibel.
- Boenninghausen, C. v. (n.d.). "*The Relationship of Remedies*". Retrieved from The Hahnemann Institute: <http://www.hahnemanninstitute.com/html/articles.html>
- Boenninghausen, C. v. "The Value of High Potencies". In Radar, *Encyclopaedia Homeopathica*. Archibel.
- Close, S. The Genius of Homeopathy. In Radar, *Encyclopaedia Homeopathica*. Whole Health Now.
- Dimitriadis, G. (2002). "*An Introduction to The Boenninghausen Repertory - Therapeutic Pocketbook Method*". Retrieved from International Academy of Classical Homeopathy: [www.vithoukaskas.com/files/pdf/AJHM_\(JAIH\)_Intro_to_TBR-Sept.2002.pdf](http://www.vithoukaskas.com/files/pdf/AJHM_(JAIH)_Intro_to_TBR-Sept.2002.pdf)
- Dimitriadis, G. (2000). "How to use this Repertory". In *The Boenninghausen Repertory*. Sydney, Australia: Southwood Press Pty.
- Dimitriadis, G. (n.d.). "*The First Repertory: Boenninghausen's model for our Profession*". Retrieved from The Hahnemann Institute: www.hahnemann-institute.com
- Dimitriadis, G. (n.d.). "*Bogus' Boenninghausen: the fundamental flaw in 'Boger's Boenninghausen'*". Retrieved from The Hahnemann Institute: www.hahnemann-institute.com
- Dimitriadis, G. (2003). *Case Studies Using the Boenninghausen Repertory*. Retrieved from International Academy of Classical Homeopathy: www.withoukaskas.com/files/pdf/AJHM-TBR_Case_Studies-20_May_2003.pdf
- Dimitriadis, G. (2004). *Homeopathic Diagnosis: Hahnemann through Boenninghausen*. Sydney, Australia: Southwood Press Pty.
- Dimitriadis, G. (2007, June 19). Personal correspondence.
- Guernsey, H. "Application of Principles of Homeopathy to Obstetrics". In Radar, *Encyclopaedia Homeopathica*. Radar.
- Hahnemann, S. "The Medicine of Experience". In Radar, *Encyclopaedia Homeopathica*. Whole Health Now.
- Hahnemann, S. (1893). *The Organon of the Medical Art. 6th Edition. Translated by R.E. Dudgeon*.
- Howard, W. (n.d.). "*Bringing Back the Baron*". Retrieved from Homeopathy West: www.homeopathywest.com/pdfs/articles_zandvoort.pdf

Kellerstein, J. (n.d.). *"Just What Exactly is Characteristic and Peculiar in Homeopathy? A discussion of the Centrality of Homeopathy - Aphorism 153"*. Retrieved from Whole Health Now: www.wholehealthnow.com/teleconferences.html

Kellerstein, J. (n.d.). *"Treating Mental and Emotional Disorders"*. Retrieved from Whole Health Now: www.wholehealthnow.com/kelia-2.mp3

Kent, J. T. Lectures on Homeopathic Materia Medica. In Radar, *Encyclopaedia Homeopathica*. Archibel.

Roberts, H. a. The Principles and Practicability of Boenninghausen's Therapeutic Pocketbook. In Radar, *Encyclopaedia Homeopathica*. Archibel.

Taylor, W. (n.d.). *"Understanding the Boenninghausen Method"*. Retrieved from Whole Health Now: www.wholehealthnow.com/wtaylor-3.mp3

Taylor, W. (n.d.). *Taking the Case, "Symptoms by Analogy"*. Retrieved from Whole Health Now: www.wholehealthnow.com/homeopathy_pro/wt0.html

Taylor, W. (n.d.). *Taking the Case: "Characterizing Dimensions of the Totality of Symptoms"*. Retrieved from Whole Health Now: www.wholehealthnow.com/homeopathy_pro/wt3.html

Taylor, W. (n.d.). *Taking the Case: "H.N. Guernsey and the Concept of Keynotes"*. Retrieved from Whole Health Now: www.wholehealthnow.com/homeopathy_pro/wt0.html